

# EDO DRAM

**ARC1C1M16E** for 5.0V  
**ARC1V1M16E** for 3.3V

## FEATURES

- JEDEC- and industry-standard x16 timing, functions, pinouts, and packages
- High-performance CMOS silicon-gate process
- Single power supply (+3.3V ±0.3V or 5V ±10%)
- All inputs, outputs and clocks are TTL-compatible
- Refresh modes: RAS#-ONLY, CAS#-BEFORE-RAS# (CBR), HIDDEN; optional self refresh (S)
- BYTE WRITE access cycles
- 1,024-cycle refresh (10 row, 10 column addresses)
- Extended Data-Out (EDO) PAGE MODE access
- 5V-tolerant inputs and I/Os on 3.3V devices

## OPTIONS

- Voltages<sup>1</sup>
  - 3.3V
  - 5V
- Refresh Addressing
  - 1,024 (1K) rows
- Packages
  - Plastic SOJ (400 mil)
  - Plastic TSOP (400 mil)
- Timing
  - 50ns access
  - 60ns access
- Refresh Rates
  - Standard Refresh (16ms period)
  - Self Refresh (128ms period)
- Operating Temperature Range
  - Commercial (0°C to +70°C)
  - Extended (-20°C to +80°C)

## MARKING

V

C

1

DJ

TG

-5

-6

None

S<sup>2</sup>

None

ET

Part Number Example:

**ARC1C1M16ETG-6**

- NOTE:** 1. The third field distinguishes the low voltage offering: V designates Vcc = 3.3V and C designates Vcc = 5V.  
2. Available only on ARC1V1M16E (3.3V)

## KEY TIMING PARAMETERS

SPEED	t <sub>RC</sub>	t <sub>RAC</sub>	t <sub>PC</sub>	t <sub>AA</sub>	t <sub>CAC</sub>	t <sub>CAS</sub>
-5	84ns	50ns	20ns	25ns	15ns	8ns
-6	104ns	60ns	25ns	30ns	17ns	10ns

## PIN ASSIGNMENT (Top View)

### 44/50-Pin TSOP

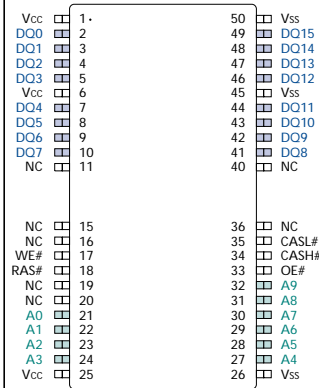

### 42-Pin SOJ

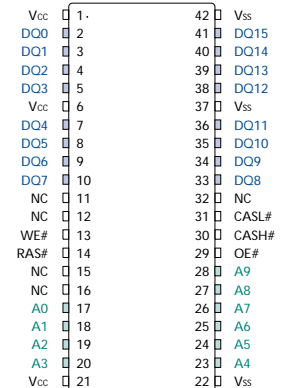

**NOTE:** The "#" symbol indicates signal is active LOW.

## 1 MEG x 16 EDO DRAM PART NUMBERS

PARTNUMBER	Vcc	REFRESH	PACKAGE	REFRESH
ARC1C1M16EDJ-x	5V	1K	400-SOJ	Standard
ARC1C1M16EDJ-xS	5V	1K	400-SOJ	Self
ARC1C1M16ETG-x	5V	1K	400-TSOP	Standard
ARC1C1M16ETG-xS	5V	1K	400-TSOP	Self
ARC1V1M16EDJ-x	3.3V	1K	400-SOJ	Standard
ARC1V1M16ETG-x	3.3V	1K	400-TSOP	Standard

**NOTE:** "-x" indicates speed grade marking under timing options.

## GENERAL DESCRIPTION

The 1 Meg x 16 is a randomly accessed, solid-state memory containing 16,777,216 bits organized in a x16 configuration. The 1 Meg x 16 has both BYTE WRITE and WORD WRITE access cycles via two CAS# pins (CASL# and CASH#). These function like a single CAS# found on other DRAMs in that either CASL# or CASH# will generate an internal CAS#.

The CAS# function and timing are determined by the first CAS# (CASL# or CASH#) to transition LOW and the last CAS# to transition back HIGH. Using only one

**GENERAL DESCRIPTION (continued)**

of the two signals results in a BYTE WRITE cycle. CASL# transitioning LOW selects an access cycle for the lower byte (DQ0-DQ7), and CASH# transitioning LOW selects an access cycle for the upper byte (DQ8-DQ15).

Each bit is uniquely addressed through the 20 address bits during READ or WRITE cycles. These are entered 10 bits (A0-A9) at a time. RAS# is used to latch the first 10 bits and CAS#, the latter 10 bits. The CAS# function also determines whether the cycle will be a refresh cycle (RAS# ONLY) or an active cycle (READ, WRITE or READ-WRITE) once RAS# goes LOW.

The CASL# and CASH# inputs internally generate a CAS# signal that functions like the single CAS# input on other DRAMs. The key difference is each CAS# input (CASL# and CASH#) controls its corresponding eight DQ inputs during WRITE accesses. CASL# controls DQ0-DQ7, and CASH# controls DQ8-DQ15. The two CAS# controls give the 1 Meg x 16 both BYTE READ and BYTE WRITE cycle capabilities.

A logic HIGH on WE# dictates read mode, while a logic LOW on WE# dictates write mode. During a WRITE cycle, data-in (D) is latched by the falling edge of WE or CAS# (CASL# or CASH#), whichever occurs last. An EARLY WRITE occurs when WE is taken LOW prior to either CAS# falling. A LATE WRITE or READ-MODIFY-WRITE occurs when WE falls after CAS# (CASL# or CASH#) was taken LOW. During EARLY WRITE cycles, the data outputs (Q) will remain High-Z, regardless of the state of OE#. During LATE WRITE or READ-MODIFY-WRITE cycles, OE# must be taken HIGH to disable the data outputs prior to applying input data. If a LATE WRITE or READ-MODIFY-WRITE is attempted while keeping OE# LOW, no WRITE will occur, and the data outputs will drive read data from the accessed location.

The 16 data inputs and 16 data outputs are routed through 16 pins using common I/O. Pin direction is controlled by OE# and WE#.

The 1 Meg x 16 DRAM must be refreshed periodically in order to retain stored data.

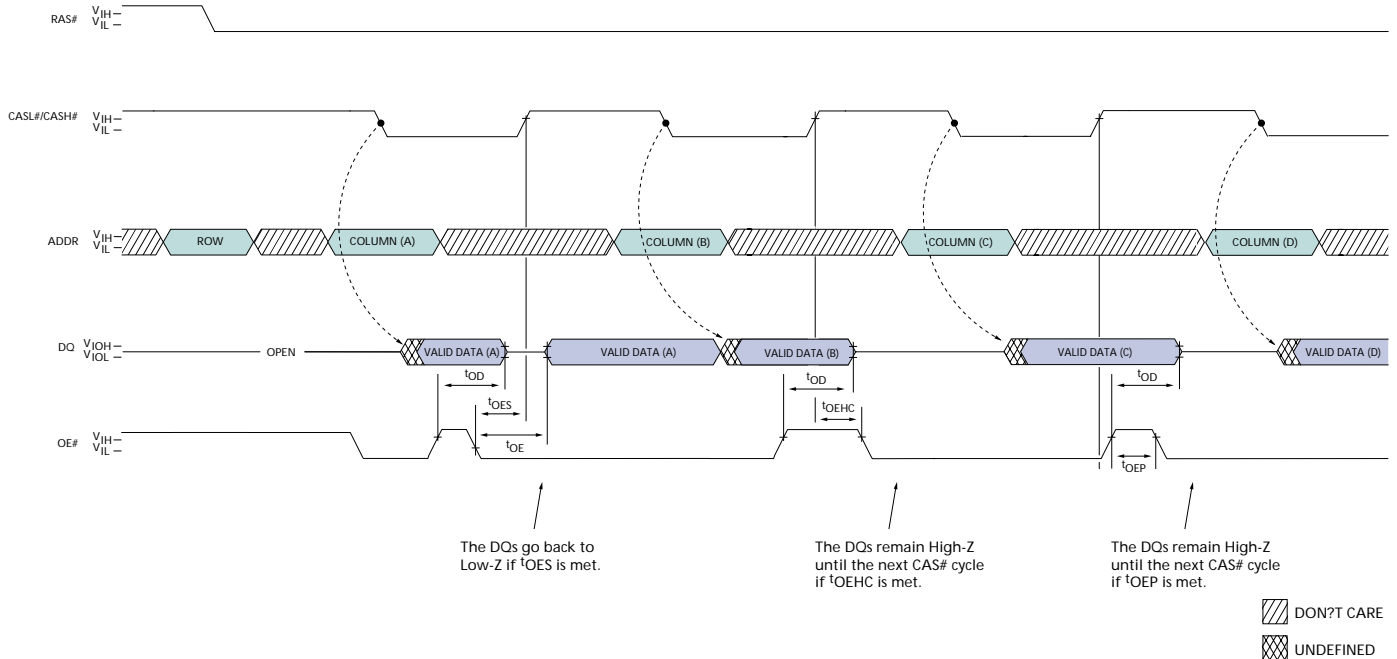

**Figure 1**  
**OE# Control of DQs**

## PAGE ACCESS

Page operations allow faster data operations (READ, WRITE or READ-MODIFY-WRITE) within a row-address-defined page boundary. The page cycle is always initiated with a row address strobed in by RAS#, followed by a column address strobed in by CAS#. Additional columns may be accessed by providing valid column addresses, strobing CAS# and holding RAS# LOW, thus executing faster memory cycles. Returning RAS# HIGH terminates the page mode of operation, i.e., closes the page.

## EDO PAGE MODE

The 1 Meg x 16 provides EDO PAGE MODE, which is an accelerated FAST-PAGE-MODE cycle. The primary advantage of EDO is the availability of data-out even after CAS# returns HIGH. EDO provides for CAS# precharge time ( $t_{CP}$ ) to occur without the output data going invalid. This elimination of CAS# output control provides for pipelined READs.

FAST-PAGE-MODE DRAMs have traditionally turned the output buffers off (High-Z) with the rising edge of CAS#. EDO-PAGE-MODE DRAMs operate like FAST-PAGE-MODE DRAMs, except data will remain valid or become valid after CAS# goes HIGH during READs, provided RAS# and OE# are held LOW. If OE# is pulsed while RAS# and CAS# are LOW, data will toggle from valid data to High-Z and back to the same valid data. If OE# is toggled or pulsed after CAS# goes HIGH

while RAS# remains LOW, data will transition to and remain High-Z (refer to Figure 1). WE# can also perform the function of disabling the output drivers under certain conditions, as shown in Figure 2.

During an application, if the DQ outputs are wire OR'ed, OE# must be used to disable idle banks of DRAMs. Alternatively, pulsing WE# to the idle banks during CAS# HIGH time will also High-Z the outputs. Independent of OE# control, the outputs will disable after  $t_{OFF}$ , which is referenced from the rising edge of RAS# or CAS#, whichever occurs last.

## BYTE ACCESS CYCLE

The BYTE WRITES and BYTE READS are determined by the use of CASL# and CASH#. Enabling CASL# selects a lower BYTE access (DQ0-DQ7). Enabling CASH# selects an upper BYTE access (DQ8-DQ15). Enabling both CASL# and CASH# selects a WORD WRITE cycle.

The 1 Meg x 16 may be viewed as two 1 Meg x 8 DRAMs that have common input controls, with the exception of the CAS# inputs. Figure 3 illustrates the BYTE WRITE and WORD WRITE cycles.

Additionally, both bytes must always be of the same mode of operation if both bytes are active. A CAS# precharge must be satisfied prior to changing modes of operation between the upper and lower bytes. For example, an EARLY WRITE on one byte and a LATE WRITE on the other byte are not allowed during the same cycle.

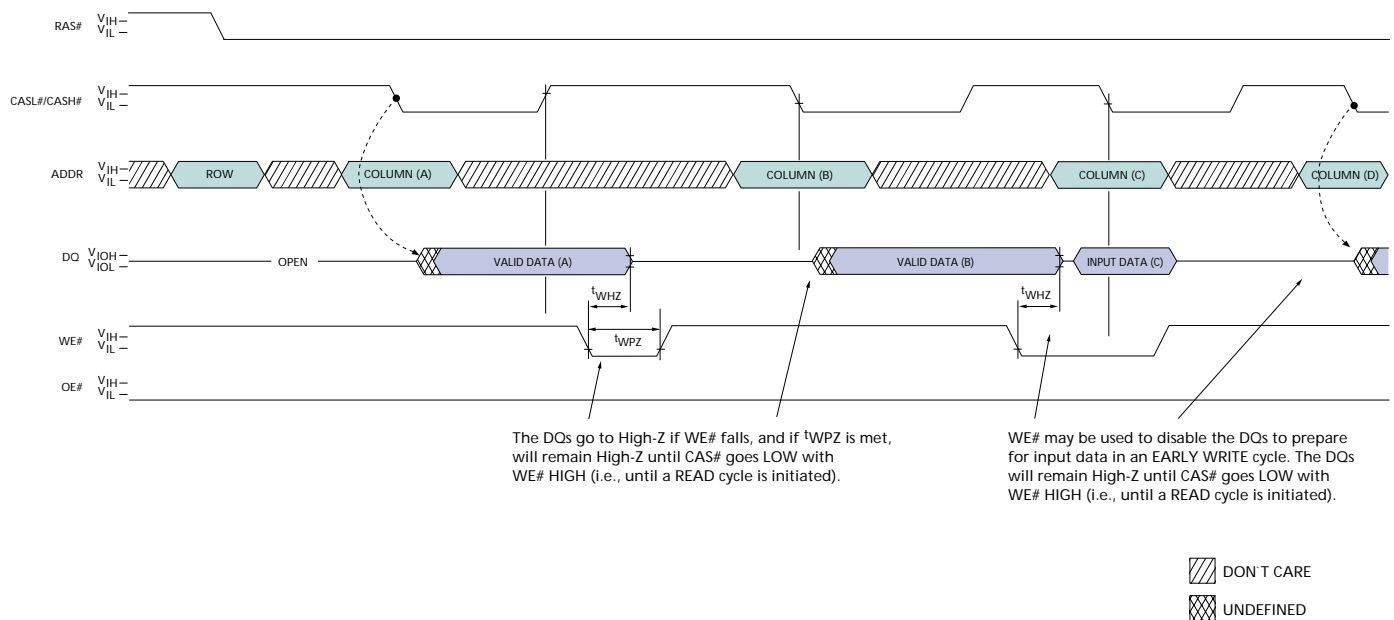

Figure 2  
WE# Control of DQs

However, an EARLY WRITE on one byte and a LATE WRITE on the other byte, after a CAS# precharge has been satisfied, are permissible.

### DRAM REFRESH

Preserve correct memory cell data by maintaining power and executing any RAS# cycle (READ, WRITE) or RAS# REFRESH cycle (RAS#-ONLY, CBR or HIDDEN) so that all 1,024 combinations of RAS# addresses are executed within  $t_{REF}^{(MAX)}$ , regardless of sequence. The CBR, EXTENDED and SELF REFRESH cycles will invoke the internal refresh counter for automatic RAS# addressing.

An optional self refresh mode is available on the "S" version. The self refresh feature is initiated by performing a CBR REFRESH cycle and holding RAS# LOW for the specified  $t_{RASS}$ . The "S" option allows the user the choice of a fully static, low-power data retention mode or a dynamic refresh mode at the extended refresh period of 128ms, or 125 $\mu$ s per row, when using a

distributed CBR REFRESH. This refresh rate can be applied during normal operation, as well as during a standby or battery backup mode.

The self refresh mode is terminated by driving RAS# HIGH for a minimum time of  $t_{RPS}$ . This delay allows for the completion of any internal refresh cycles that may be in process at the time of the RAS# LOW-to-HIGH transition. If the DRAM controller uses a distributed refresh sequence, a burst refresh is not required upon exiting self refresh. However, if the DRAM controller utilizes a RAS#-ONLY or burst refresh sequence, all 1,024 rows must be refreshed within the average internal refresh rate, prior to the resumption of normal operation.

### STANDBY

Returning RAS# and CAS# HIGH terminates a memory cycle and decreases chip current to a reduced standby level. The chip is preconditioned for the next cycle during the RAS# HIGH time.

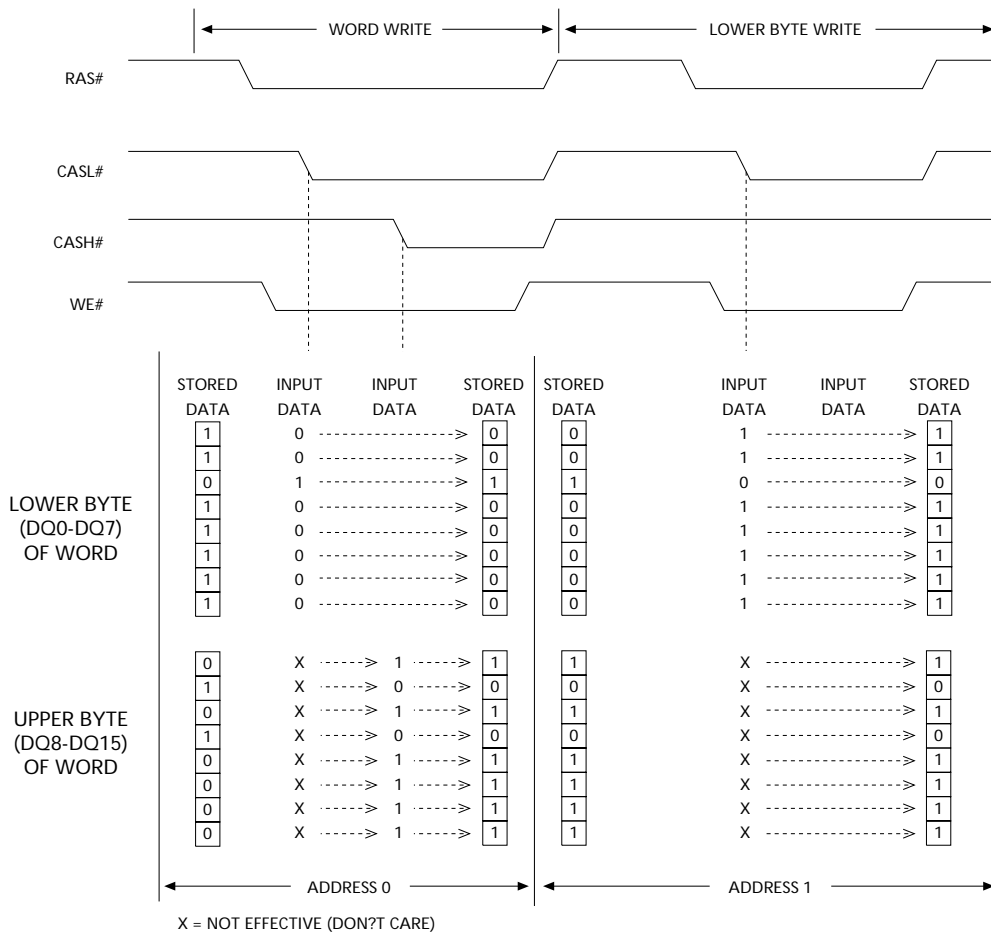
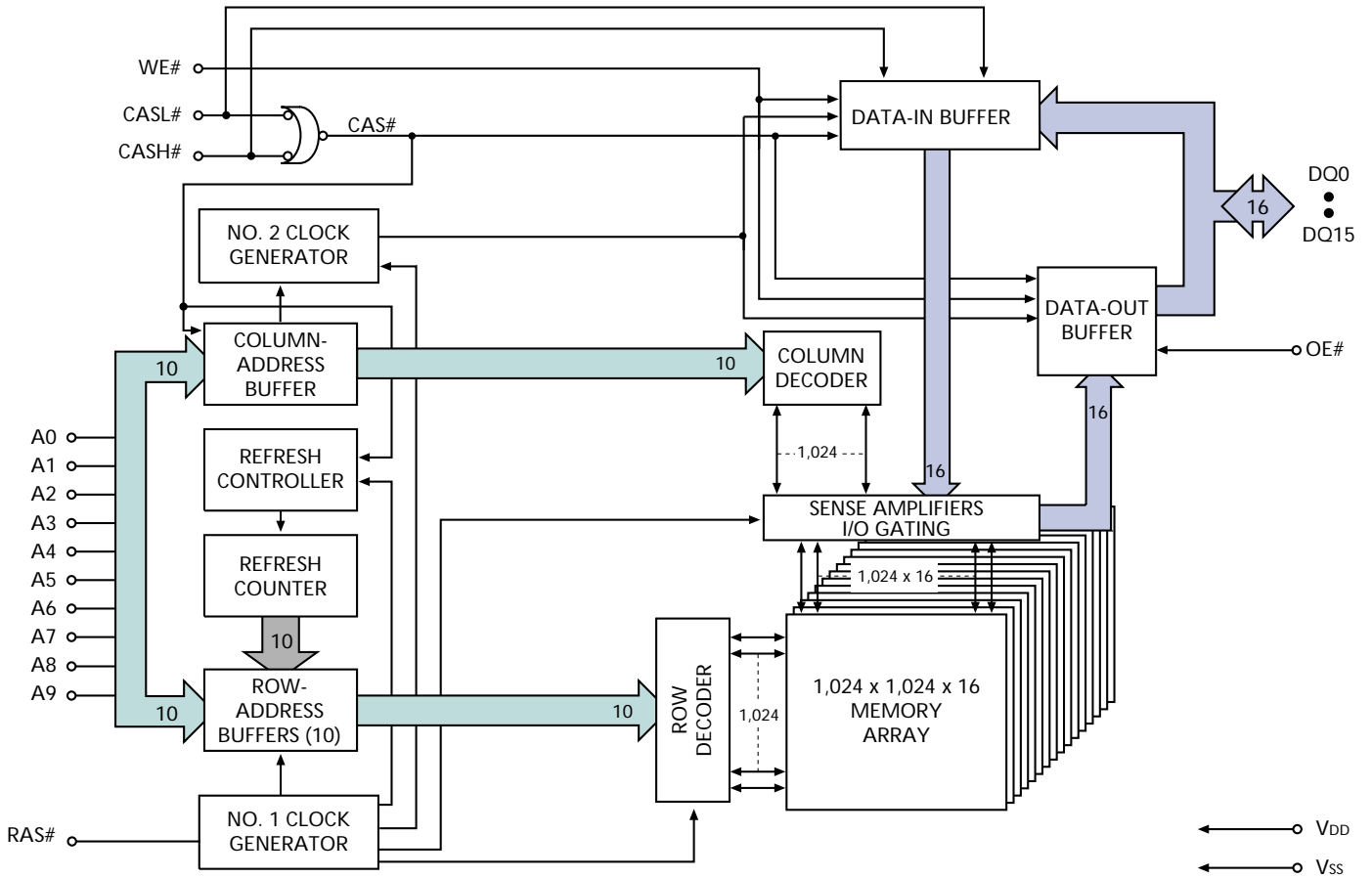

Figure 3  
WORD and BYTE WRITE Example

FUNCTIONAL BLOCK DIAGRAM



**ABSOLUTE MAXIMUM RATINGS\***

Voltage on Vcc Pin Relative to Vss  
 3.3V ..... -1V to +4.6V  
 5V ..... -1V to +7V

Voltage on NC, Inputs or I/O Pins Relative to Vss:  
 3.3V ..... -1V to +5.5V  
 5V ..... -1V to +7V

Operating Temperature  
 T<sub>A</sub> (commercial) ..... 0°C to +70°C  
 T<sub>A</sub> (extended) ..... -20°C to +80°C

Storage Temperature (plastic) ..... -55°C to +150°C  
 Power Dissipation ..... 1W  
 Short Circuit Output Current ..... 50mA

\*Stresses greater than those listed under “Absolute Maximum Ratings” may cause permanent damage to the device. This is a stress rating only, and functional operation of the device at these or any other conditions above those indicated in the operational sections of this specification is not implied. Exposure to absolute maximum rating conditions for extended periods may affect reliability.

**DC ELECTRICAL CHARACTERISTICS AND OPERATING CONDITIONS**

(Notes: 1; notes appear on pages 10-11)

PARAMETER/CONDITION	SYMBOL	3.3V		5V		UNITS	NOTES
		MIN	MAX	MIN	MAX		
SUPPLY VOLTAGE	V <sub>CC</sub>	3.0	3.6	4.5	5.5	V	
INPUT HIGH VOLTAGE: Valid Logic 1; All inputs, I/Os and any NC	V <sub>IH</sub>	2.0	5.5	2.4	V <sub>CC</sub> + 1	V	
INPUT LOW VOLTAGE: Valid Logic 0; All inputs, I/Os and any NC	V <sub>IL</sub>	-1.0	0.8	-0.5	0.8	V	
INPUT LEAKAGE CURRENT: Any input at V <sub>IN</sub> (0V ≤ V <sub>IN</sub> ≤ V <sub>IH</sub> [MAX]); All other pins not under test = 0V	I <sub>I</sub>	-2	2	-2	2	μA	4
OUTPUT HIGH VOLTAGE: I <sub>OUT</sub> = -2mA(3.3V), -5mA(5V)	V <sub>OH</sub>	2.4	-	2.4	-	V	
OUTPUT LOW VOLTAGE: I <sub>OUT</sub> = 2mA(3.3V), 4.2mA(5V)	V <sub>OL</sub>	-	0.4	-	0.4	V	
OUTPUT LEAKAGE CURRENT: Any output at V <sub>OUT</sub> (0V ≤ V <sub>OUT</sub> ≤ 5.5V); DQ is disabled and in High-Z state	I <sub>OZ</sub>	-5	5	-5	5	μA	

**I<sub>CC</sub> OPERATING CONDITIONS AND MAXIMUM LIMITS**

(Notes: 1, 2, 3, 5, 8; notes appear on pages 10-11); (V<sub>CC</sub>[MIN] ≤ V<sub>CC</sub> ≤ V<sub>CC</sub>[MAX])

PARAMETER/CONDITION	SYMBOL	SPEED	3.3V	5V	UNITS	NOTES
STANDBY CURRENT: TTL (RAS# = CAS# = V <sub>IH</sub> )	I <sub>CC1</sub>	ALL	1	2	mA	
STANDBY CURRENT: CMOS (non-"S" version only) (RAS# = CAS# = other inputs = V <sub>DD</sub> - 0.2V)	I <sub>CC2</sub>	ALL	500	500	μA	
STANDBY CURRENT: CMOS ("S" version only) (RAS# = CAS# = other inputs = V <sub>DD</sub> - 0.2V)	I <sub>CC2</sub>	ALL	150	150	μA	
OPERATING CURRENT: Random READ/WRITE Average power supply current (RAS#, CAS#, address cycling: t <sub>RC</sub> = t <sub>RC</sub> [MIN])	I <sub>CC3</sub>	-5 -6	180 170	190 180	mA	6
OPERATING CURRENT: EDO PAGE MODE Average power supply current (RAS# = V <sub>IL</sub> , CAS#, address cycling: t <sub>PC</sub> = t <sub>PC</sub> [MIN])	I <sub>CC4</sub>	-5 -6	140 130	150 140	mA	6
REFRESH CURRENT: RAS#-ONLY Average power supply current (RAS# cycling, CAS# = V <sub>IH</sub> : t <sub>RC</sub> = t <sub>RC</sub> [MIN])	I <sub>CC5</sub>	-5 -6	180 170	190 180	mA	
REFRESH CURRENT: CBR Average power supply current (RAS#, CAS#, address cycling: t <sub>RC</sub> = t <sub>RC</sub> [MIN])	I <sub>CC6</sub>	-5 -6	180 170	180 170	mA	7, 9
REFRESH CURRENT: Extended ("S" version only) Average power supply current: CAS# = 0.2V or CBR cycling; RAS# = t <sub>RAS</sub> (MIN); WE# = V <sub>DD</sub> - 0.2V; A0-A10, OE# and D <sub>IN</sub> = V <sub>DD</sub> - 0.2V or 0.2V (D <sub>IN</sub> may be left open); t <sub>RC</sub> = 125μs	I <sub>CC7</sub>	ALL	300	300	μA	7, 9
REFRESH CURRENT: Self ("S" version only) Average power supply current: CBR with RAS# ≥ t <sub>RASS</sub> (MIN) and CAS# held LOW; WE# = V <sub>DD</sub> - 0.2V; A0-A10, OE# and D <sub>IN</sub> = V <sub>DD</sub> - 0.2V or 0.2V (D <sub>IN</sub> may be left open)	I <sub>CC8</sub>	ALL	300	300	μA	7, 9

## CAPACITANCE

(Notes: 1, 2, 3, 5, 8; notes appear on pages 10-11)

PARAMETER	SYMBOL	MAX	UNITS	NOTES
Input Capacitance: Addresses	C <sub>i1</sub>	5	pF	
Input Capacitance: RAS#, CASL#,CASH#, WE#, OE#	C <sub>i2</sub>	7	pF	
Input/Output Capacitance: DQ	C <sub>i0</sub>	7	pF	

## AC ELECTRICAL CHARACTERISTICS

(Notes: 2, 3, 9, 10, 11, 12; notes appear on pages 10-11); (V<sub>CC</sub>[MIN] ≤ V<sub>CC</sub> ≤ V<sub>CC</sub>[MAX])

AC CHARACTERISTICS	PARAMETER	SYMBOL	-5		-6		UNITS	NOTES
			MIN	MAX	MIN	MAX		
Access time from column address	t <sub>AA</sub>			25		30	ns	
Column-address setup to CAS# precharge	t <sub>ACH</sub>	12			15		ns	
Column-address hold time (referenced to RAS#)	t <sub>AR</sub>	38			45		ns	
Column-address setup time	t <sub>ASC</sub>	0			0		ns	25
Row-address setup time	t <sub>ASR</sub>	0			0		ns	25
Column address to WE# delay time	t <sub>AWD</sub>	42			49		ns	13
Access time from CAS#	t <sub>CAC</sub>		13			15	ns	14, 25
Column-address hold time	t <sub>CAH</sub>	8			10		ns	25
CAS# pulse width	t <sub>CAS</sub>	8	10,000		10	10,000	ns	27
CAS# LOW to "Don't Care" during Self Refresh	t <sub>CHD</sub>	15			15		ns	
CAS# hold time (CBR Refresh)	t <sub>CHR</sub>	8			10		ns	7, 26
Last CAS# going LOW to first CAS# to return HIGH	t <sub>CLCH</sub>	5			5		ns	28
CAS# to output in Low-Z	t <sub>CLZ</sub>	0			0		ns	26
Data output hold after next CAS# LOW	t <sub>COH</sub>	3			3		ns	
CAS# precharge time	t <sub>CP</sub>	8			10		ns	15, 30
Access time from CAS# precharge	t <sub>CPA</sub>		28			35	ns	26
CAS# to RAS# precharge time	t <sub>CRP</sub>	5			5		ns	26
CAS# hold time	t <sub>CSH</sub>	38			45		ns	26
CAS# setup time (CBR Refresh)	t <sub>CSR</sub>	5			5		ns	7, 25
CAS# to WE# delay time	t <sub>CWD</sub>	28			35		ns	13, 25
WRITE command to CAS# lead time	t <sub>CWL</sub>	8			10		ns	26
Data-in hold time	t <sub>DH</sub>	8			10		ns	16, 25
Data-in setup time	t <sub>DS</sub>	0			0		ns	16, 25
Output disable	t <sub>OD</sub>	0	12		0	15	ns	
Output enable	t <sub>OE</sub>		12			15	ns	17
OE# hold time from WE# during READ-MODIFY-WRITE cycle	t <sub>OEH</sub>	8			10		ns	18
OE# HIGH hold from CAS# HIGH	t <sub>OEHC</sub>	5			10		ns	18
OE# HIGH pulse width	t <sub>OEP</sub>	5			5		ns	
OE# LOW to CAS# HIGH setup time	t <sub>OES</sub>	4			5		ns	
Output buffer turn-off delay	t <sub>OFF</sub>	0	12		0	15	ns	20, 26

**AC ELECTRICAL CHARACTERISTICS (continued)**

(Notes: 2, 3, 9, 10, 11, 12; notes appear on pages 10-11); (V<sub>cc</sub>[MIN] ≤ V<sub>cc</sub> ≤ V<sub>cc</sub>[MAX])

AC CHARACTERISTICS PARAMETER	SYMBOL	-5		-6		UNITS	NOTES
		MIN	MAX	MIN	MAX		
OE# setup prior to RAS# during HIDDEN REFRESH cycle	t <sup>ORD</sup>	0		0		ns	
EDO-PAGE-MODE READ or WRITE cycle time	t <sup>PC</sup>	20		25		ns	31
EDO-PAGE-MODE READ-WRITE cycle time	t <sup>PRWC</sup>	47		56		ns	31
Access time from RAS#	t <sup>RAC</sup>		50		60	ns	19
RAS# to column-address delay time	t <sup>RAD</sup>	9		12		ns	21
Row address hold time	t <sup>RAH</sup>	9		10		ns	
RAS# pulse width	t <sup>RAS</sup>	50	10,000	60	10,000	ns	
RAS# pulse width (EDO PAGE MODE)	t <sup>RASP</sup>	50	125,000	60	125,000	ns	
RAS# pulse width during Self Refresh	t <sup>RASS</sup>	100		100		μs	
Random READ or WRITE cycle time	t <sup>RC</sup>	84		104		ns	
RAS# to CAS# delay time	t <sup>RCD</sup>	11		14		ns	22, 25
READ command hold time (referenced to CAS#)	t <sup>RCH</sup>	0		0		ns	23, 27
READ command setup time	t <sup>RCS</sup>	0		0		ns	25
Refresh period (1,024 cycles)	t <sup>REF</sup>		16		16	ms	
Refresh period (1,024 cycles) S version	t <sup>REF</sup>		128		128	ms	
RAS# precharge time	t <sup>RP</sup>	30		40		ns	
RAS# to CAS# precharge time	t <sup>RPC</sup>	5		5		ns	
RAS# precharge time exiting Self Refresh	t <sup>RPS</sup>	90		105		ns	
READ command hold time (referenced to RAS#)	t <sup>RRH</sup>	0		0		ns	23
RAS# hold time	t <sup>RSH</sup>	13		15		ns	32
READ-WRITE cycle time	t <sup>RWC</sup>	116		140		ns	
RAS# to WE# delay time	t <sup>RWD</sup>	67		79		ns	13
WRITE command to RAS# lead time	t <sup>RWL</sup>	13		15		ns	
Transition time (rise or fall)	t <sup>T</sup>	2	50	2	50	ns	
WRITE command hold time	t <sup>WCH</sup>	8		10		ns	32
WRITE command hold time (referenced to RAS#)	t <sup>WCR</sup>	38		45		ns	
WE# command setup time	t <sup>WCS</sup>	0		0		ns	13, 25
Output disable delay from WE#	t <sup>WHZ</sup>	0	12	0	15	ns	
WRITE command pulse width	t <sup>WP</sup>	5		5		ns	
WE# pulse to disable at CAS# HIGH	t <sup>WPZ</sup>	10		10		ns	
WE# hold time (CBR Refresh)	t <sup>WRH</sup>	8		10		ns	
WE# setup time (CBR Refresh)	t <sup>WRP</sup>	8		10		ns	

## NOTES

1. All voltages referenced to Vss.
2. The minimum specifications are used only to indicate cycle time at which proper operation over the full temperature range ( $0^{\circ}\text{C} \leq T_A \leq 70^{\circ}\text{C}$  for commercial) and ( $-20^{\circ}\text{C} \leq T_A \leq 80^{\circ}\text{C}$  for extended) is ensured.
3. An initial pause of  $100\mu\text{s}$  is required after power-up, followed by eight RAS# refresh cycles (RAS#-ONLY or CBR with WE# HIGH), before proper device operation is ensured. The eight RAS# cycle wake-ups should be repeated any time the  $t_{\text{REF}}$  refresh requirement is exceeded.
4. NC pins are assumed to be left floating and are not tested for leakage.
5.  $I_{\text{CC}}$  is dependent on output loading and cycle rates. Specified values are obtained with minimum cycle time and the outputs open.
6. Column address changed once each cycle.
7. Enables on-chip refresh and address counters.
8. This parameter is sampled.  $V_{\text{DD}} = +3.3\text{V}$ ;  $f = 1\text{ MHz}$ .
9. AC characteristics assume  $t_{\text{T}} = 2.5\text{ns}$ .
10.  $V_{\text{IH}}$  (MIN) and  $V_{\text{IL}}$  (MAX) are reference levels for measuring timing of input signals. Transition times are measured between  $V_{\text{IH}}$  and  $V_{\text{IL}}$  (or between  $V_{\text{IL}}$  and  $V_{\text{IH}}$ ).
11. In addition to meeting the transition rate specification, all input signals must transit between  $V_{\text{IH}}$  and  $V_{\text{IL}}$  (or between  $V_{\text{IL}}$  and  $V_{\text{IH}}$ ) in a monotonic manner.
12. Measured with a load equivalent to two TTL gates and  $100\text{pF}$ ; and  $V_{\text{OL}} = 0.8\text{V}$  and  $V_{\text{OH}} = 2\text{V}$ .
13.  $t_{\text{WCS}}$ ,  $t_{\text{RWD}}$ ,  $t_{\text{AWD}}$ , and  $t_{\text{CWD}}$  are not restrictive operating parameters.  $t_{\text{WCS}}$  applies to EARLY WRITE cycles.  $t_{\text{RWD}}$ ,  $t_{\text{AWD}}$  and  $t_{\text{CWD}}$  apply to READ-MODIFY-WRITE cycles. If  $t_{\text{WCS}} \geq t_{\text{WCS}}$  (MIN), the cycle is an EARLY WRITE cycle and the data output will remain an open circuit throughout the entire cycle. If  $t_{\text{WCS}} < t_{\text{WCS}}$  (MIN) and  $t_{\text{RWD}} \geq t_{\text{RWD}}$  (MIN),  $t_{\text{AWD}} \geq t_{\text{AWD}}$  (MIN) and  $t_{\text{CWD}} \geq t_{\text{CWD}}$  (MIN), the cycle is a READ-MODIFY-WRITE and the data output will contain data read from the selected cell. If neither of the above conditions is met, the state of data-out is indeterminate. OE# held HIGH and WE# taken LOW after CAS# goes LOW results in a LATE WRITE (OE#-controlled) cycle.  $t_{\text{WCS}}$ ,  $t_{\text{RWD}}$ ,  $t_{\text{CWD}}$  and  $t_{\text{AWD}}$  are not applicable in a LATE WRITE cycle.
14. Assumes that  $t_{\text{RCD}} \geq t_{\text{RCD}}$  (MAX).
15. If CAS# is LOW at the falling edge of RAS#, Q will be maintained from the previous cycle. To initiate a new cycle and clear the data-out buffer, CAS# must be pulsed HIGH for  $t_{\text{CP}}$ .
16. These parameters are referenced to CAS# leading edge in EARLY WRITE cycles and WE# leading edge in LATE WRITE or READ-MODIFY-WRITE cycles.
17. If OE# is tied permanently LOW, LATE WRITE, or READ-MODIFY-WRITE operations are not permissible and should not be attempted. Additionally, WE# must be pulsed during CAS# HIGH time in order to place I/O buffers in High-Z.
18. LATE WRITE and READ-MODIFY-WRITE cycles must have both  $t_{\text{OD}}$  and  $t_{\text{OEH}}$  met (OE# HIGH during WRITE cycle) in order to ensure that the output buffers will be open during the WRITE cycle. The DQs will provide the previously read data if CAS# remains LOW and OE# is taken back LOW after  $t_{\text{OEH}}$  is met. If CAS# goes HIGH prior to OE# going back LOW, the DQs will remain open.
19. Assumes that  $t_{\text{RCD}} < t_{\text{RCD}}$  (MAX). If  $t_{\text{RCD}}$  is greater than the maximum recommended value shown in this table,  $t_{\text{RAC}}$  will increase by the amount that  $t_{\text{RCD}}$  exceeds the value shown.
20.  $t_{\text{OFF}}$  (MAX) defines the time at which the output achieves the open circuit condition and is not referenced to  $V_{\text{OH}}$  or  $V_{\text{OL}}$ . It is referenced from the rising edge of RAS# or CAS#, whichever occurs last.
21. The  $t_{\text{RAD}}$  (MAX) limit is no longer specified.  $t_{\text{RAD}}$  (MAX) was specified as a reference point only. If  $t_{\text{RAD}}$  was greater than the specified  $t_{\text{RAD}}$  (MAX) limit, then access time was controlled exclusively by  $t_{\text{AA}}$  ( $t_{\text{RAC}}$  and  $t_{\text{CAC}}$  no longer applied). With or without the  $t_{\text{RAD}}$  (MAX) limit,  $t_{\text{AA}}$ ,  $t_{\text{RAC}}$ , and  $t_{\text{CAC}}$  must always be met.
22. The  $t_{\text{RCD}}$  (MAX) limit is no longer specified.  $t_{\text{RCD}}$  (MAX) was specified as a reference point only. If  $t_{\text{RCD}}$  was greater than the specified  $t_{\text{RCD}}$  (MAX) limit, then access time was controlled exclusively by  $t_{\text{CAC}}$  ( $t_{\text{RAC}}$  [MIN] no longer applied). With or without the  $t_{\text{RCD}}$  limit,  $t_{\text{AA}}$  and  $t_{\text{CAC}}$  must always be met.
23. Either  $t_{\text{RCH}}$  or  $t_{\text{RRH}}$  must be satisfied for a READ cycle.
24. The first CAS#x edge to transition LOW.
25. Output parameter (DQx) is referenced to corresponding CAS# input; DQ0-DQ7 by CASL# and DQ8-DQ15 by CASH#.

**NOTES (continued)**

- 26. Each CAS#x must meet minimum pulse width.
- 27. The last CAS#x edge to transition HIGH.
- 28. Last falling CAS#x edge to first rising CAS#x edge.
- 29. Last rising CAS#x edge to first falling CAS#x edge.
- 30. Last rising CAS#x edge to next cycle's last rising CAS#x edge.

- 31. Last CAS#x to go LOW.
- 32. A HIDDEN REFRESH may also be performed after a WRITE cycle. In this case, WE# is LOW and OE# is HIGH.

READ CYCLE

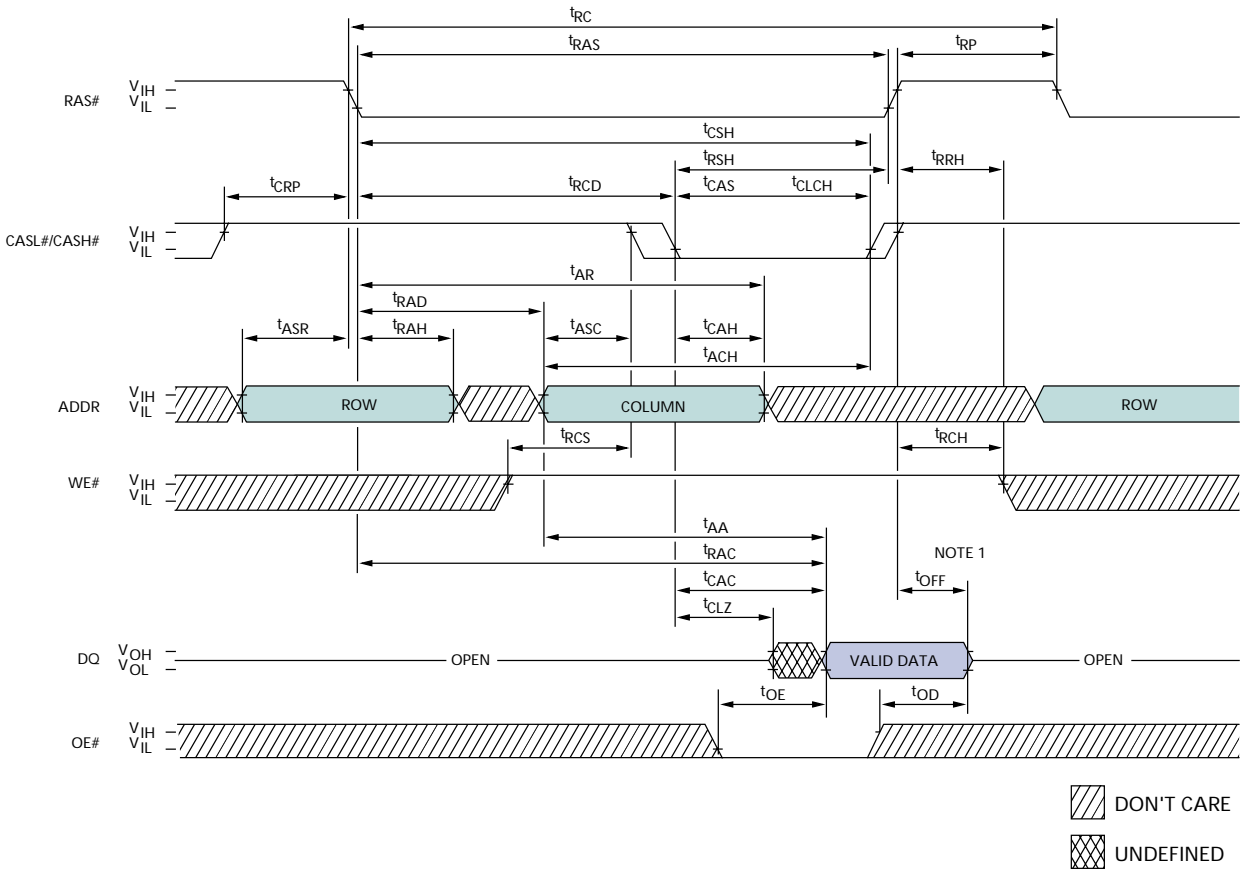

TIMING PARAMETERS

SYMBOL	-5		-6		UNITS
	MIN	MAX	MIN	MAX	
$t_{AA}$		25		30	ns
$t_{ACH}$	12		15		ns
$t_{AR}$	38		45		ns
$t_{ASC}$	0		0		ns
$t_{ASR}$	0		0		ns
$t_{CAC}$		13		15	ns
$t_{CAH}$	8		10		ns
$t_{CAS}$	8	10,000	10	10,000	ns
$t_{CLCH}$	5		5		ns
$t_{CLZ}$	0		0		ns
$t_{CRP}$	5		5		ns
$t_{CSH}$	38		45		ns
$t_{OD}$	0	12	0	15	ns

SYMBOL	-5		-6		UNITS
	MIN	MAX	MIN	MAX	
$t_{OE}$		12		15	ns
$t_{OFF}$	0	12	0	15	ns
$t_{RAC}$		50		60	ns
$t_{RAD}$	9		12		ns
$t_{RAH}$	9		10		ns
$t_{RAS}$	50	10,000	60	10,000	ns
$t_{RC}$	84		104		ns
$t_{RCD}$	11		14		ns
$t_{RCH}$	0		0		ns
$t_{RCS}$	0		0		ns
$t_{RP}$	30		40		ns
$t_{RRH}$	0		0		ns
$t_{RSH}$	13		15		ns

NOTE: 1.  $t_{OFF}$  is referenced from rising edge of RAS# or CAS#, whichever occurs last.

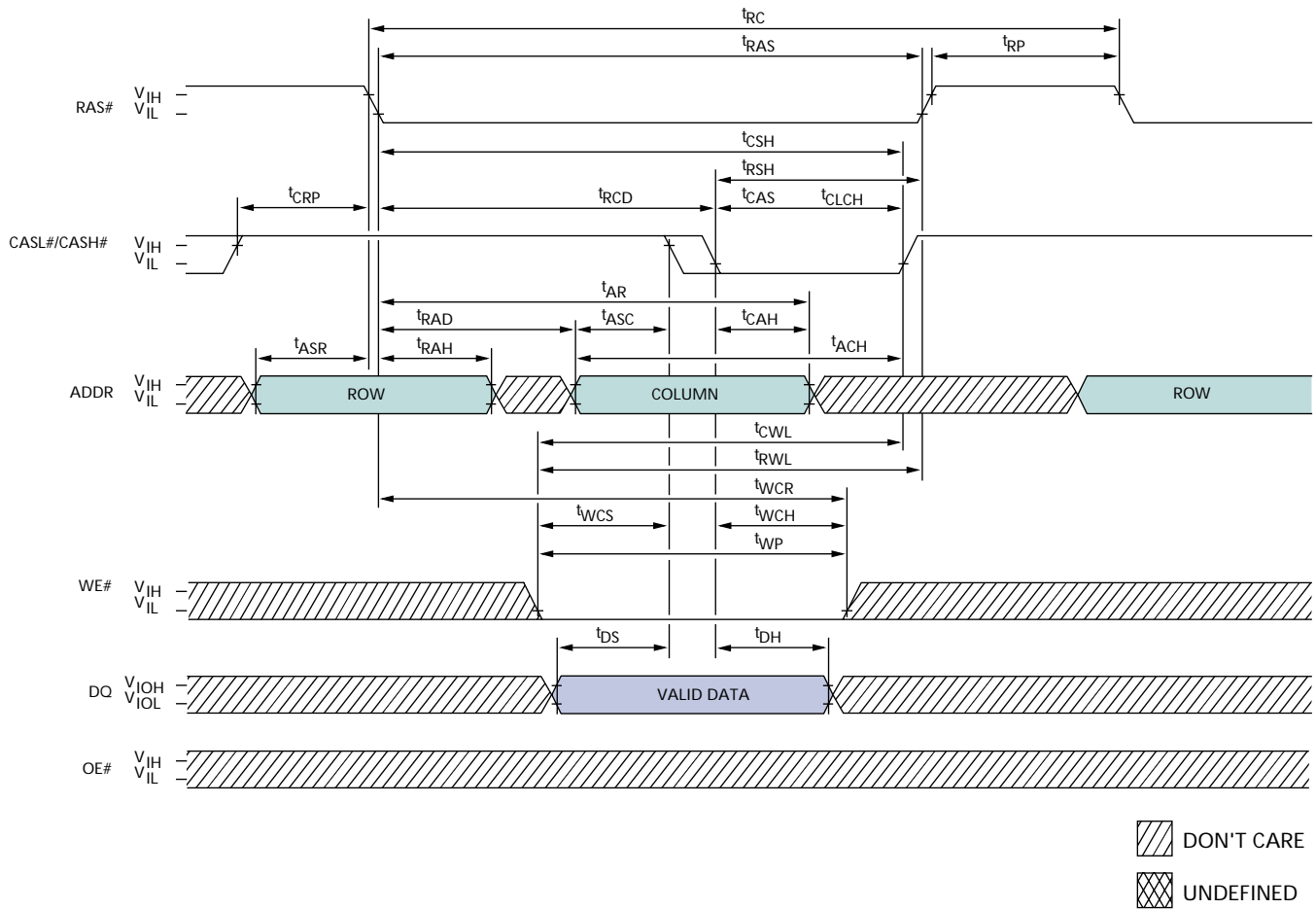

## TIMING PARAMETERS

SYMBOL	-5		-6		UNITS
	MIN	MAX	MIN	MAX	
t <sub>ACH</sub>	12		15		ns
t <sub>AR</sub>	38		45		ns
t <sub>ASC</sub>	0		0		ns
t <sub>ASR</sub>	0		0		ns
t <sub>CAH</sub>	8		10		ns
t <sub>CAS</sub>	8	10,000	10	10,000	ns
t <sub>CLCH</sub>	5		5		ns
t <sub>CRP</sub>	5		5		ns
t <sub>CSH</sub>	38		45		ns
t <sub>CWL</sub>	8		10		ns
t <sub>DH</sub>	8		10		ns
t <sub>DS</sub>	0		0		ns

SYMBOL	-5		-6		UNITS
	MIN	MAX	MIN	MAX	
t <sub>RAD</sub>	9		12		ns
t <sub>RAH</sub>	9		10		ns
t <sub>RAS</sub>	50	10,000	60	10,000	ns
t <sub>RC</sub>	84		104		ns
t <sub>RCD</sub>	11		14		ns
t <sub>RP</sub>	30		40		ns
t <sub>RSH</sub>	13		15		ns
t <sub>RWL</sub>	13		15		ns
t <sub>WCH</sub>	8		10		ns
t <sub>WCR</sub>	38		45		ns
t <sub>WCS</sub>	0		0		ns
t <sub>WP</sub>	5		5		ns

**READ-WRITE CYCLE**  
(LATE WRITE and READ-MODIFY-WRITE cycles)

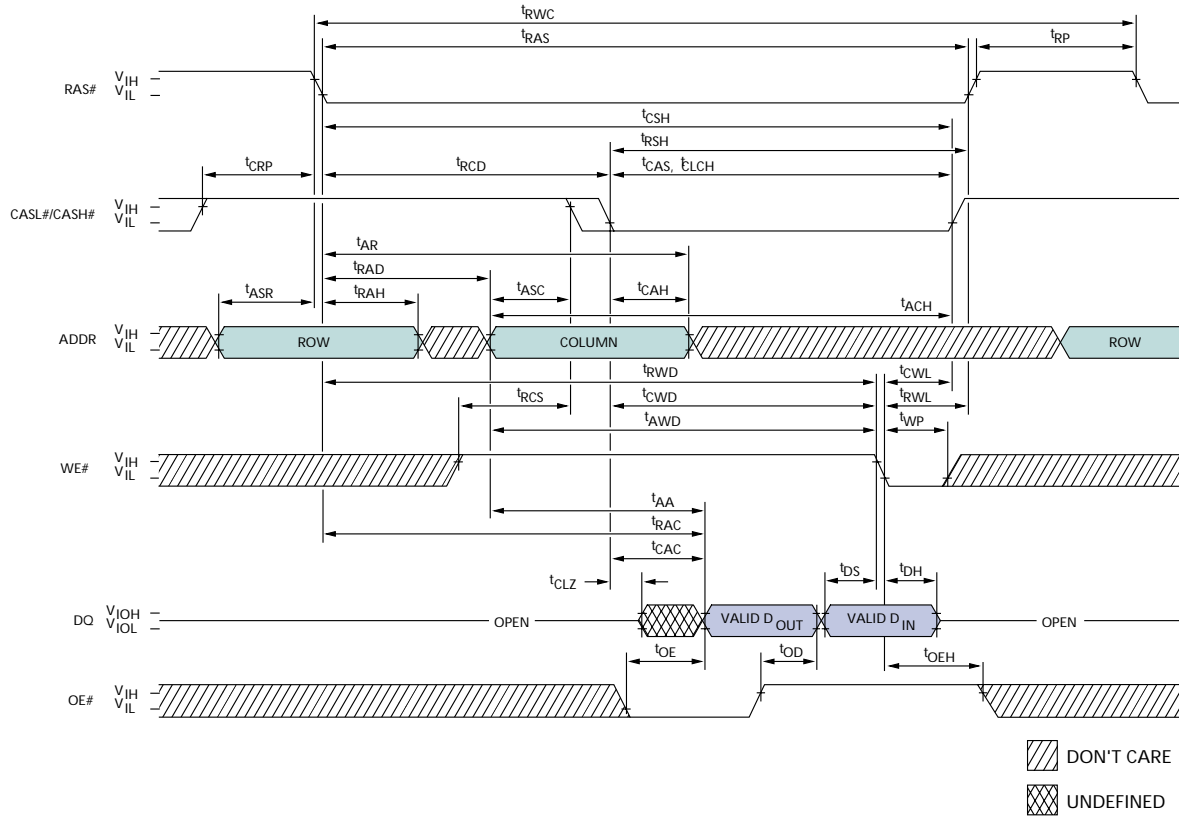

**TIMING PARAMETERS**

SYMBOL	-5		-6		UNITS
	MIN	MAX	MIN	MAX	
tAA		25		30	ns
tACH	12		15		ns
tAR	38		45		ns
tASC	0		0		ns
tAWD	42		49		ns
tASR	0		0		ns
tCAC		13		15	ns
tCAH	8		10		ns
tCAS	8	10,000	10	10,000	ns
tCLCH	5		5		ns
tCLZ	0		0		ns
tCRP	5		5		ns
tCSH	38		45		ns
tCWD	28		35		ns
tCWL	8		10		ns
tDH	8		10		ns

SYMBOL	-5		-6		UNITS
	MIN	MAX	MIN	MAX	
tDS	0		0		ns
tOD	0	12	0	15	ns
tOE		12		15	ns
tOEH	8		10		ns
tRAC		50		60	ns
tRAD	9		12		ns
tRAH	9		10		ns
tRAS	50	10,000	60	10,000	ns
tRCD	11		14		ns
tRCS	0		0		ns
tRP	30		40		ns
tRSH	13		15		ns
tRWC	116		140		ns
tRWD	67		79		ns
tRWL	13		15		ns
tWP	5		5		ns



EDO-PAGE-MODE EARLY WRITE CYCLE

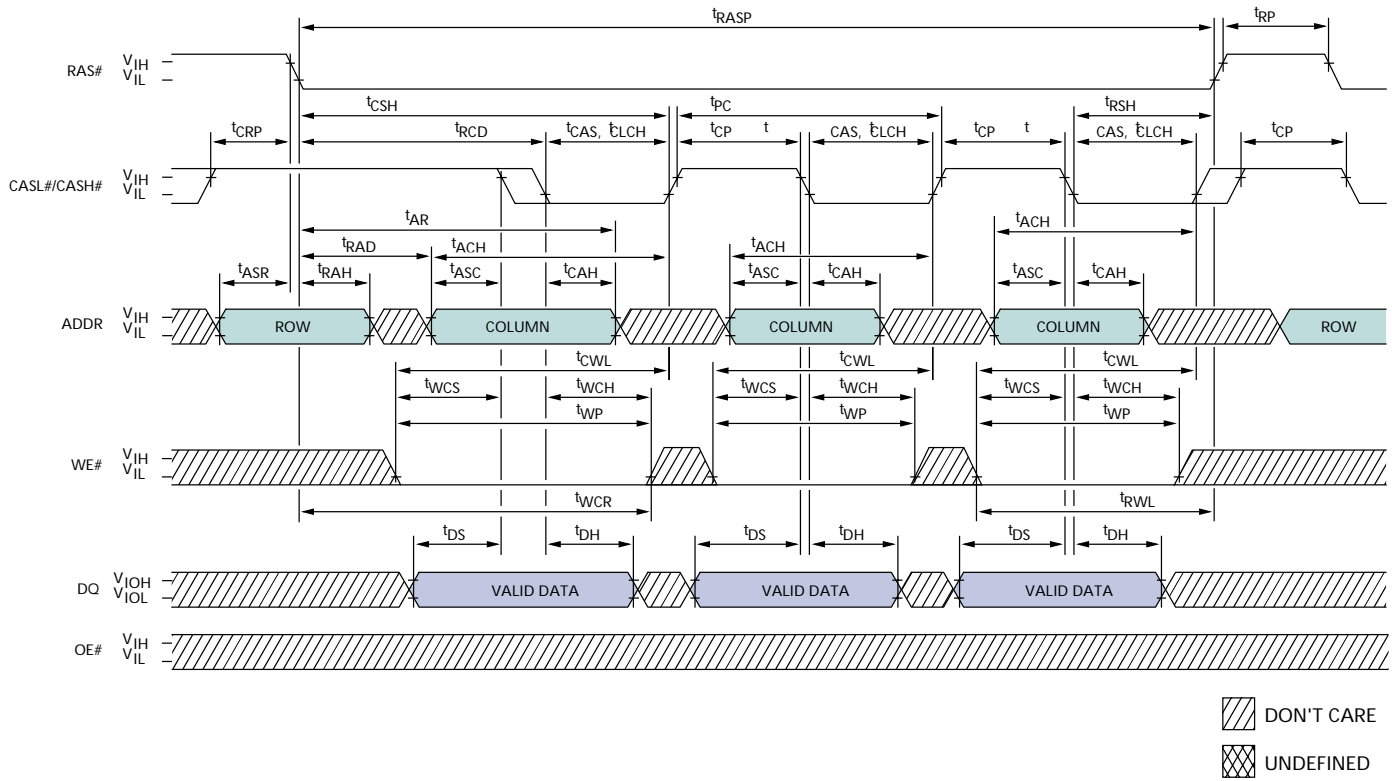

TIMING PARAMETERS

SYMBOL	-5		-6		UNITS
	MIN	MAX	MIN	MAX	
t <sup>t</sup> ACH	12		15		ns
t <sup>t</sup> AR	38		45		ns
t <sup>t</sup> ASC	0		0		ns
t <sup>t</sup> ASR	0		0		ns
t <sup>t</sup> CAH	8		10		ns
t <sup>t</sup> CAS	8	10,000	10	10,000	ns
t <sup>t</sup> CLCH	5		5		ns
t <sup>t</sup> CP	8		10		ns
t <sup>t</sup> CRP	5		5		ns
t <sup>t</sup> CSH	38		45		ns
t <sup>t</sup> CWL	8		10		ns
t <sup>t</sup> DH	8		10		ns
t <sup>t</sup> DS	0		0		ns

SYMBOL	-5		-6		UNITS
	MIN	MAX	MIN	MAX	
t <sup>t</sup> PC	20		25		ns
t <sup>t</sup> RAD	9		12		ns
t <sup>t</sup> RAH	9		10		ns
t <sup>t</sup> RASP	50	125,000	60	125,000	ns
t <sup>t</sup> RCD	11		14		ns
t <sup>t</sup> RP	30		40		ns
t <sup>t</sup> RSH	13		15		ns
t <sup>t</sup> RWL	13		15		ns
t <sup>t</sup> WCH	8		10		ns
t <sup>t</sup> WCR	38		45		ns
t <sup>t</sup> WCS	0		0		ns
t <sup>t</sup> WP	5		5		ns



**EDO-PAGE-MODE READ EARLY WRITE CYCLE**  
(Pseudo READ-MODIFY-WRITE)

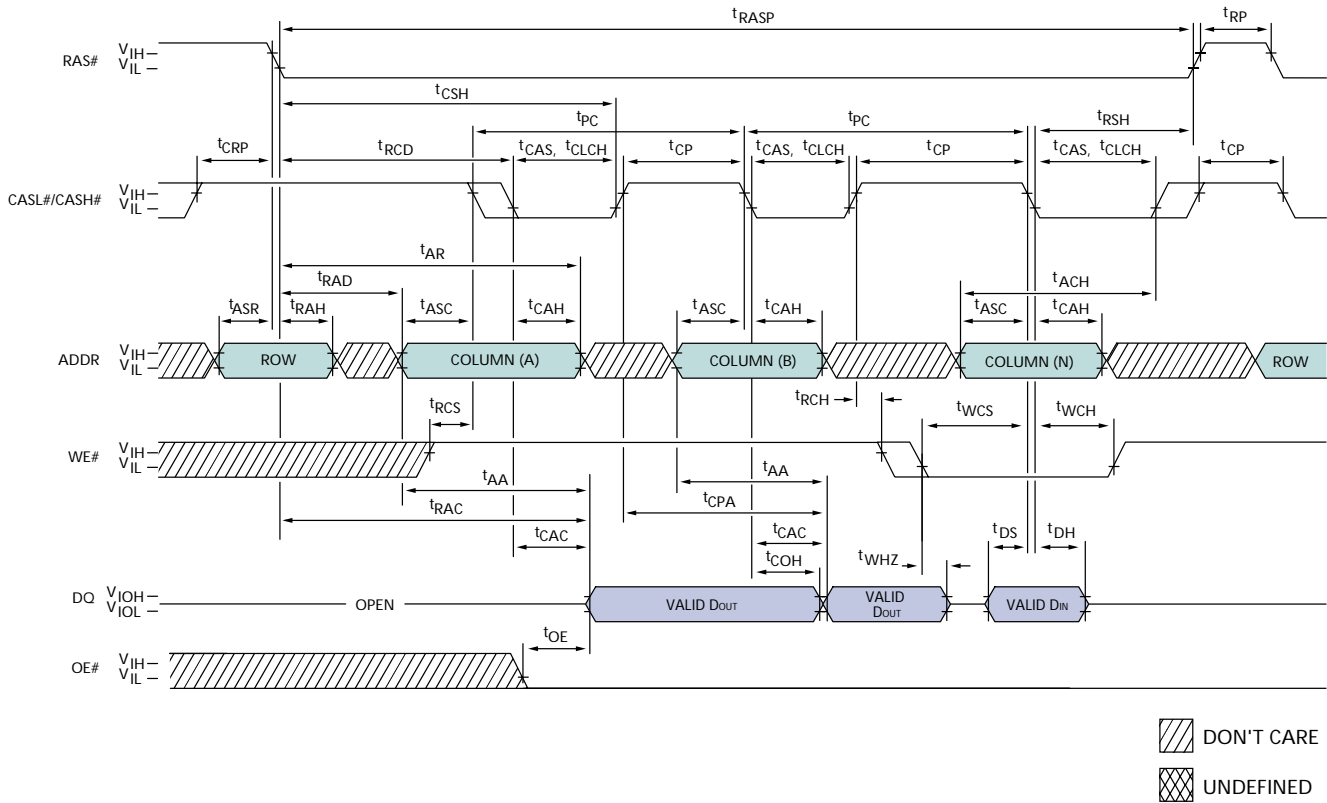

**TIMING PARAMETERS**

SYMBOL	-5		-6		UNITS
	MIN	MAX	MIN	MAX	
t <sub>AA</sub>		25		30	ns
t <sub>ACH</sub>	12		15		ns
t <sub>AR</sub>	38		45		ns
t <sub>ASC</sub>	0		0		ns
t <sub>ASR</sub>	0		0		ns
t <sub>CAC</sub>		13		15	ns
t <sub>CAH</sub>	8		10		ns
t <sub>CAS</sub>	8	10,000	10	10,000	ns
t <sub>CLCH</sub>	5		5		ns
t <sub>COH</sub>	3		3		ns
t <sub>CP</sub>	8		10		ns
t <sub>CPA</sub>		28		35	ns
t <sub>CRP</sub>	5		5		ns
t <sub>CSH</sub>	38		45		ns
t <sub>DH</sub>	8		10		ns

SYMBOL	-5		-6		UNITS
	MIN	MAX	MIN	MAX	
t <sub>DS</sub>	0		0		ns
t <sub>OE</sub>		12		15	ns
t <sub>PC</sub>	20		25		ns
t <sub>RAC</sub>		50		60	ns
t <sub>RAD</sub>	9		12		ns
t <sub>RAH</sub>	9		10		ns
t <sub>RASP</sub>	50	125,000	60	125,000	ns
t <sub>RCD</sub>	11		14		ns
t <sub>RCH</sub>	0		0		ns
t <sub>RCS</sub>	0		0		ns
t <sub>RP</sub>	30		40		ns
t <sub>RSH</sub>	13		15		ns
t <sub>WCH</sub>	8		10		ns
t <sub>WCS</sub>	0		0		ns
t <sub>WHZ</sub>	0	12	0	15	ns

**READ CYCLE**  
(with WE#-controlled disable)

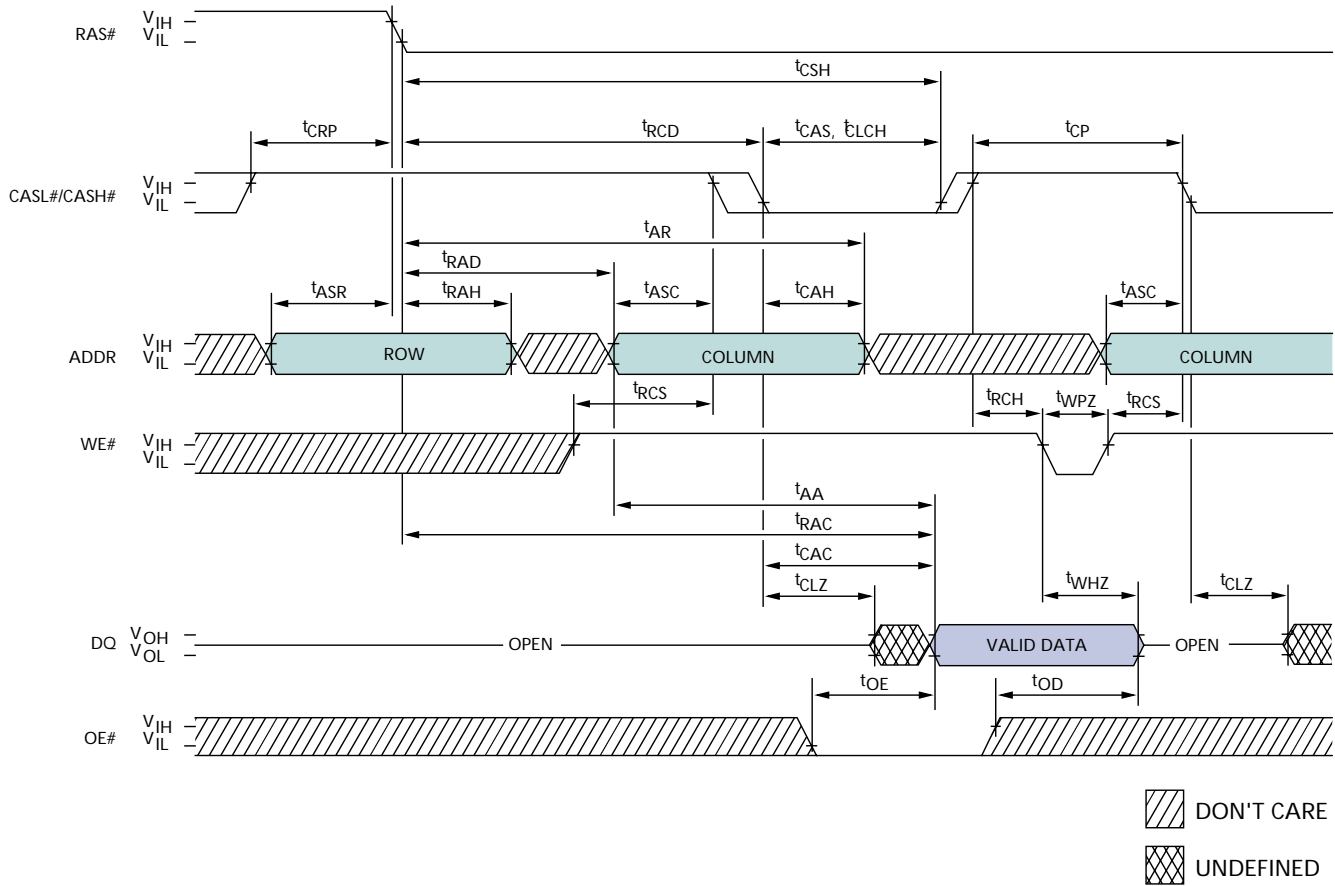

**TIMING PARAMETERS**

SYMBOL	-5		-6		UNITS
	MIN	MAX	MIN	MAX	
t <sub>AA</sub>		25		30	ns
t <sub>AR</sub>	38		45		ns
t <sub>ASC</sub>	0		0		ns
t <sub>ASR</sub>	0		0		ns
t <sub>CAC</sub>		13		15	ns
t <sub>CAH</sub>	8		10		ns
t <sub>CAS</sub>	8	10,000	10	10,000	ns
t <sub>CLCH</sub>	5		5		ns
t <sub>CLZ</sub>	0		0		ns
t <sub>CP</sub>	8		10		ns
t <sub>CRP</sub>	5		5		ns

SYMBOL	-5		-6		UNITS
	MIN	MAX	MIN	MAX	
t <sub>CSH</sub>	38		45		ns
t <sub>OD</sub>	0	12	0	15	ns
t <sub>OE</sub>		12		15	ns
t <sub>RAC</sub>		50		60	ns
t <sub>RAD</sub>	9		12		ns
t <sub>RAH</sub>	9		10		ns
t <sub>RCD</sub>	11		14		ns
t <sub>RCH</sub>	0		0		ns
t <sub>RCS</sub>	0		0		ns
t <sub>WHZ</sub>	0	12	0	15	ns
t <sub>WPZ</sub>	10		10		ns

**RAS#-ONLY REFRESH CYCLE**  
(OE# and WE# = DON'T CARE)

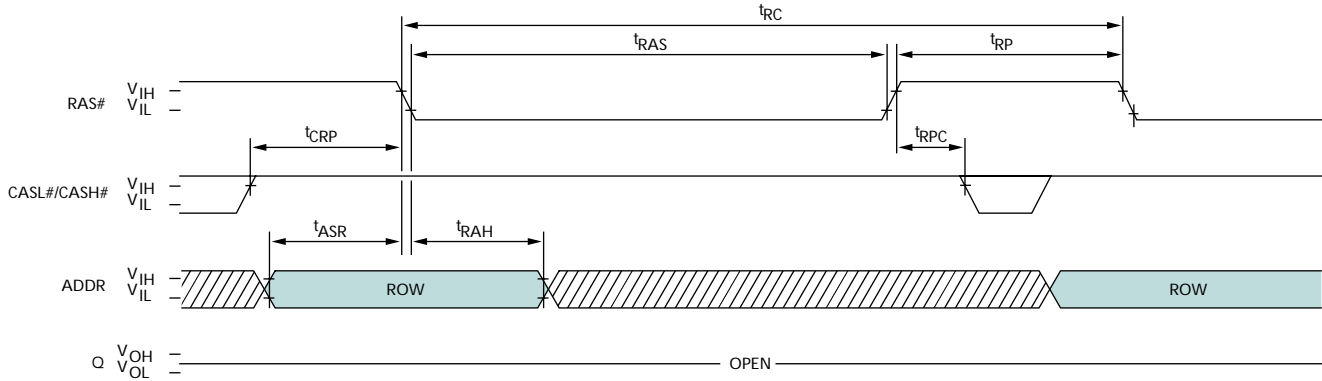

**CBR REFRESH CYCLE**  
(Addresses and OE# = DON'T CARE)

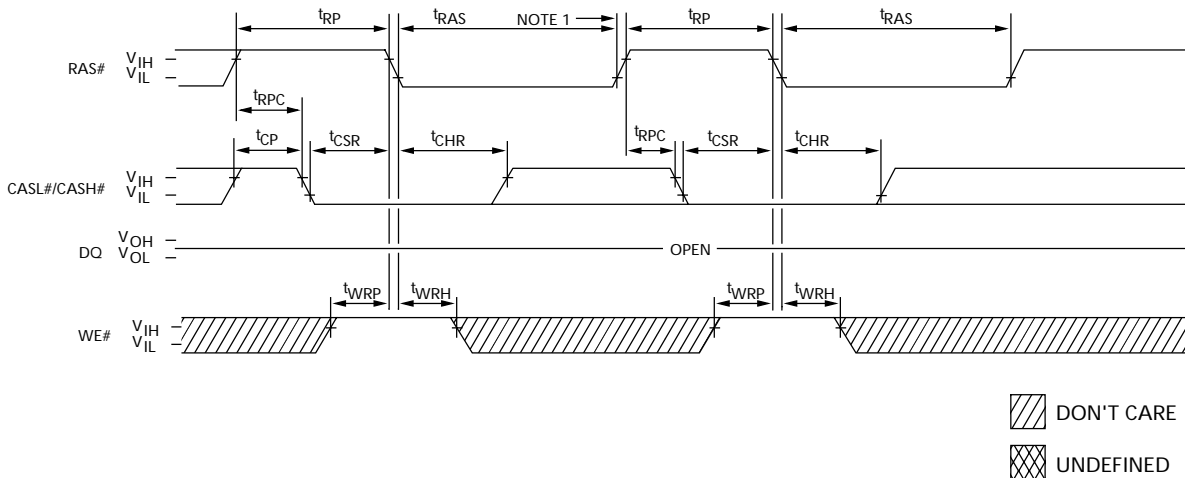

**TIMING PARAMETERS**

SYMBOL	-5		-6		UNITS
	MIN	MAX	MIN	MAX	
t <sub>ASR</sub>	0		0		ns
t <sub>CHR</sub>	8		10		ns
t <sub>CP</sub>	8		10		ns
t <sub>CRP</sub>	5		5		ns
t <sub>CSR</sub>	5		5		ns
t <sub>RAH</sub>	9		10		ns

SYMBOL	-5		-6		UNITS
	MIN	MAX	MIN	MAX	
t <sub>RAS</sub>	50	10,000	60	10,000	ns
t <sub>RC</sub>	84		104		ns
t <sub>RP</sub>	30		40		ns
t <sub>RPC</sub>	5		5		ns
t <sub>WRH</sub>	8		10		ns
t <sub>WRP</sub>	8		10		ns

**NOTE:** 1. End of first CBR REFRESH cycle.

**HIDDEN REFRESH CYCLE**  
(WE# = HIGH; OE# = LOW)

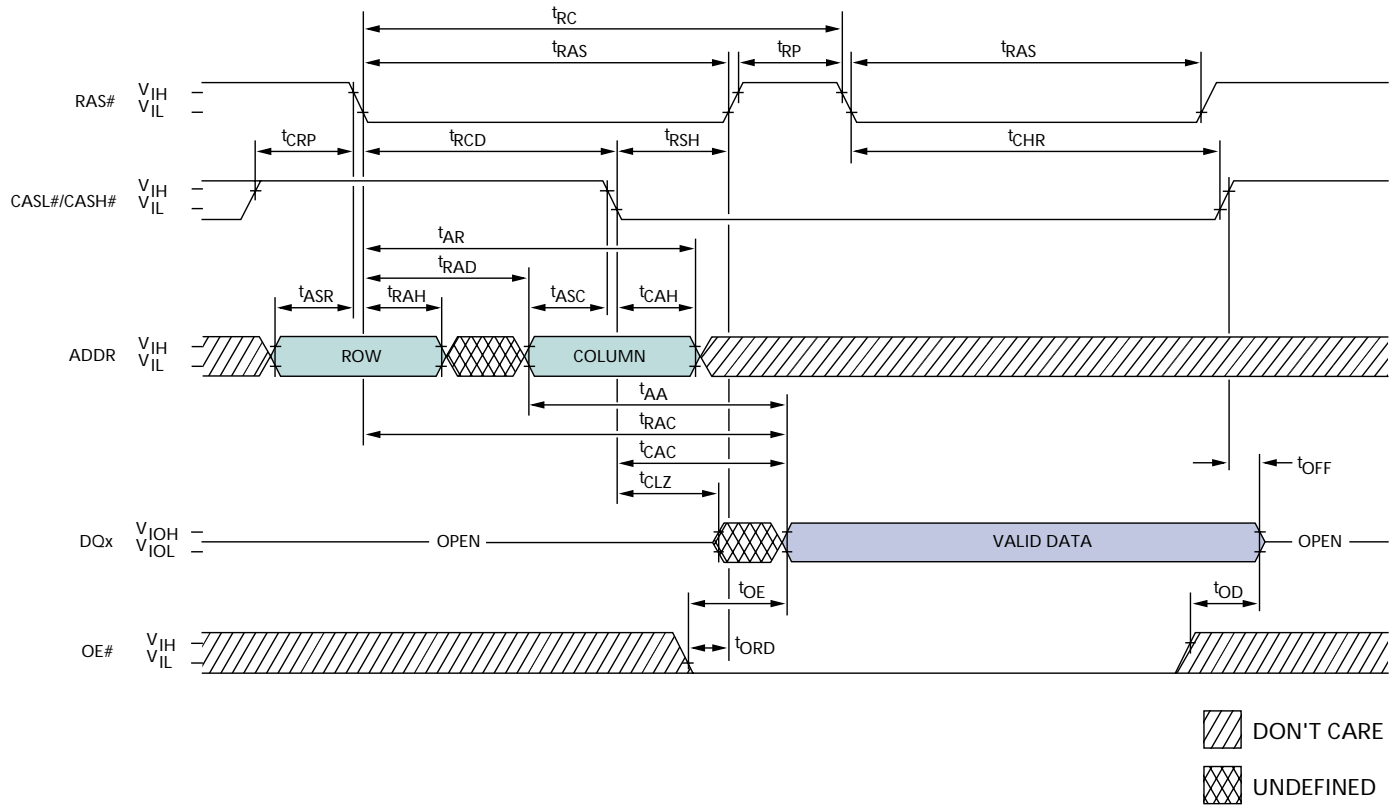

**TIMING PARAMETERS**

SYMBOL	-5		-6		UNITS
	MIN	MAX	MIN	MAX	
tAA		25		30	ns
tAR	38		45		ns
tASC	0		0		ns
tASR	0		0		ns
tCAC		13		15	ns
tCAH	8		10		ns
tCHR	8		10		ns
tCLZ	0		0		ns
tCRP	5		5		ns
tOD	0	12	0	15	ns

SYMBOL	-5		-6		UNITS
	MIN	MAX	MIN	MAX	
tOE		12		15	ns
tOFF	0	12	0	15	ns
tORD	0		0		ns
tRAC		50		60	ns
tRAD	9		12		ns
tRAH	9		10		ns
tRAS	50	10,000	60	10,000	ns
tRCD	11		14		ns
tRP	30		40		ns
tRSH	13		15		ns

**SELF REFRESH CYCLE**  
(Addresses and OE# = DON'T CARE)

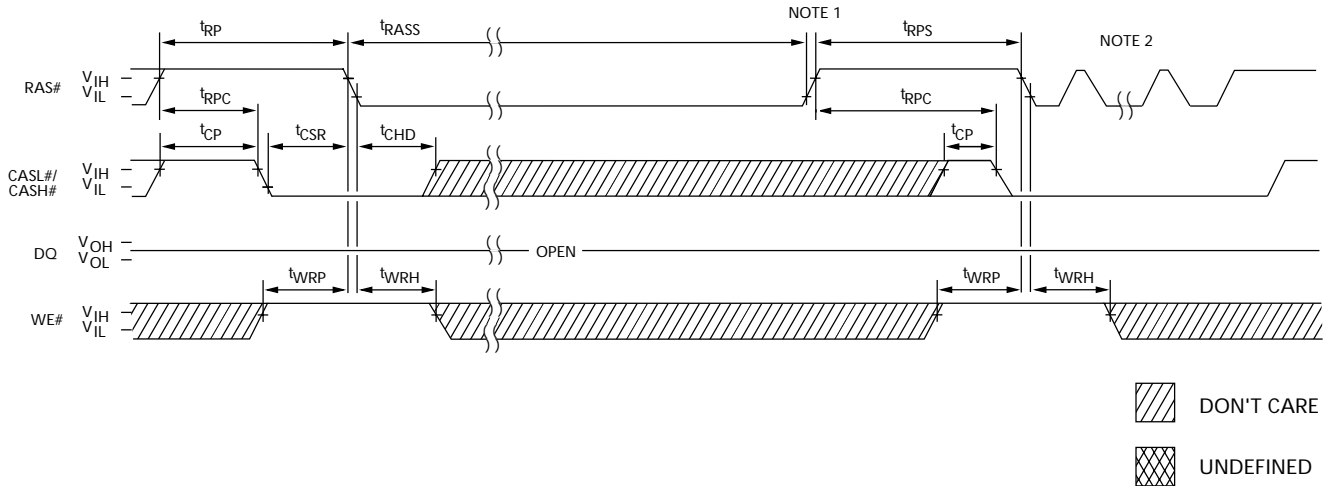

**TIMING PARAMETERS**

SYMBOL	-5		-6		UNITS
	MIN	MAX	MIN	MAX	
$t_{CHD}$	15		15		ns
$t_{CLCH}$	5		5		ns
$t_{CP}$	8		10		ns
$t_{CSR}$	5		5		ns
$t_{RASS}$	100		100		$\mu$ s

SYMBOL	-5		-6		UNITS
	MIN	MAX	MIN	MAX	
$t_{RP}$	30		40		ns
$t_{RPC}$	5		5		ns
$t_{RPS}$	90		105		ns
$t_{WRH}$	8		10		ns
$t_{WRP}$	8		10		ns

**NOTE:** 1. Once  $t_{RASS}$  (MIN) is met and RAS# remains LOW, the DRAM will enter self refresh mode.  
2. Once  $t_{RPS}$  is satisfied, a complete burst of all rows should be executed.

44/50-PIN PLASTIC TSOP (400 mil)

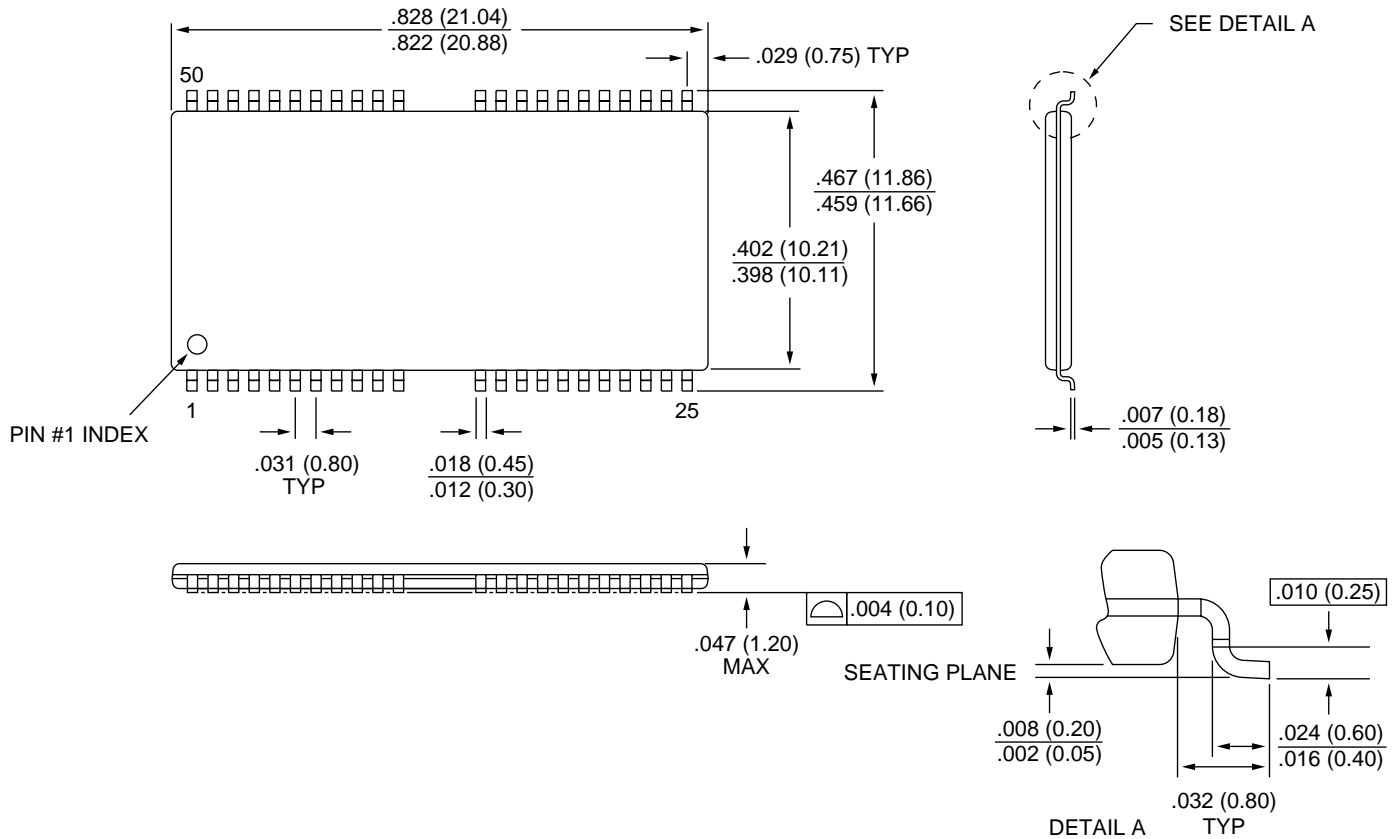

- NOTE:**
1. All dimensions in inches (millimeters)  $\frac{\text{MAX}}{\text{MIN}}$  or typical where noted.
  2. Package width and length do not include mold protrusion; allowable mold protrusion is .01" per side.

42-PIN PLASTIC SOJ (400 mil)

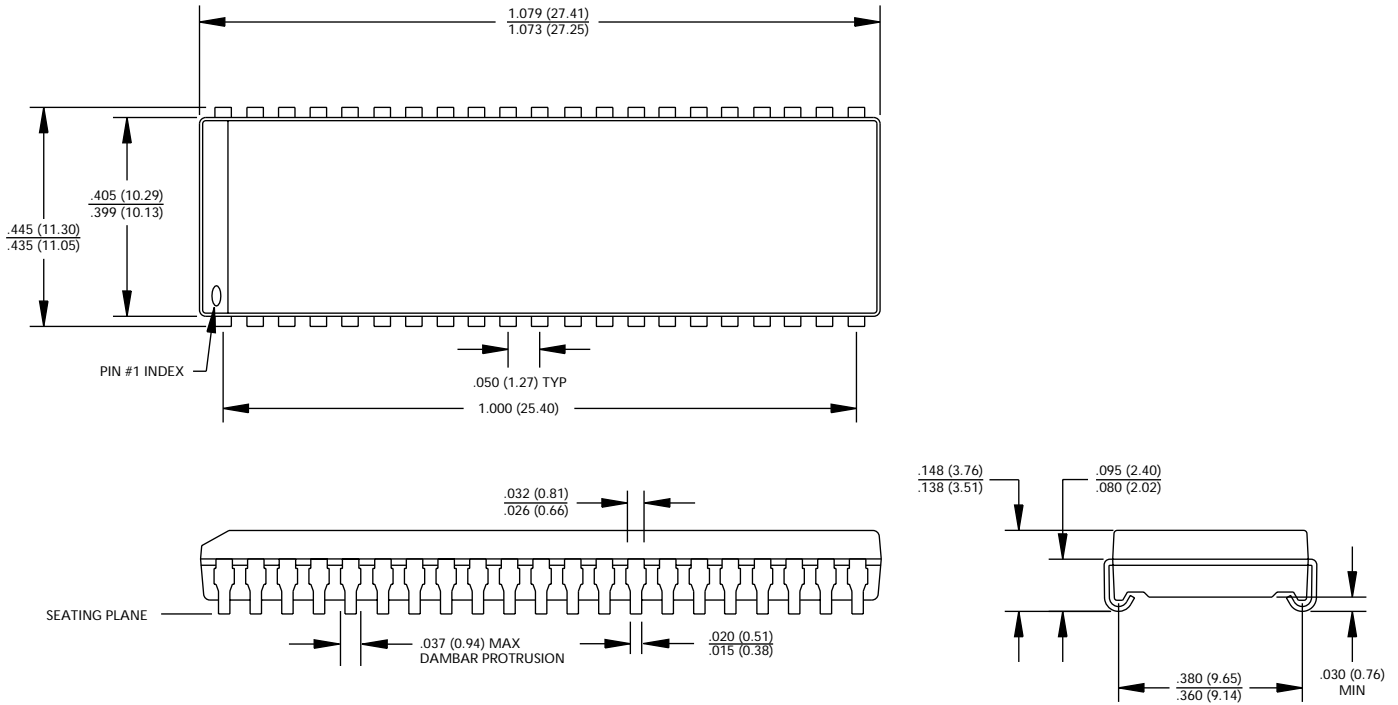

- NOTE:** 1. All dimensions in inches (millimeters)  $\frac{\text{MAX}}{\text{MIN}}$  or typical where noted.  
2. Package width and length do not include mold protrusion; allowable mold protrusion is .01" per side.



4378 Enterprise Street, Fremont, CA 94538, Tel: 510-656-9988  
Internet: <http://www.quadrant.com>

Quadrant Components is a registered trademark and the Quadrant Components logo are trademarks of Quadrant Components, Inc.