

# 16 Mbit (x16) Enhanced Boot Block Flash Memory

## ARC28F160A3FZ

### FEATURES

- Thirty-nine erase blocks:
  - Two 4K-word boot blocks (protected)
  - Six 4K-word parameter blocks
  - Thirty-one 32K-word main memory blocks
- V<sub>CCQ</sub> and V<sub>PP</sub> balls are connected to V<sub>CC</sub> FBGA substrate.
  - 5V V<sub>PP</sub> fast programming voltage
- Address access times:
  - 90ns, 110ns at 2.7V–3.3V
- Low power consumption:
  - Standby and deep power-down mode < 1uA (typical I<sub>CC</sub>)
  - Automatic power saving feature (APS mode)
- Enhanced WRITE/ERASE SUSPEND (1us typical)
- 128-bit OTP area for security purposes
- Industry-standard command set compatibility
- Hardware block protection
- TP (output):
  - This output is connected to V<sub>CC</sub> on the FBGA substrate.
- WP# (input):
  - For correct operation of the ARC28F1603AFZ, WP# must be connected to V<sub>CC</sub> on the external PCB.

### OPTIONS

### NUMBER

- |  |      |
|--|------|
| • Timing   |      |
| 90ns access  | -9   |
| 110ns access   | -11  |
| • Boot Block Starting Address  |      |
| Bottom (00000H)  | B    |
| • The boot block protection feature is not available on this device when WP# is connected to V <sub>CC</sub> on the external PCB |      |
| • Package  |      |
| 46-ball FBGA (6 x 8 ball grid)   | FZ   |
| • Temperature Range  |      |
| Commercial (0°C to +70°C)  | None |
| Extended (-40°C to +85°C)  | ET   |

\*Lower V<sub>CCQ</sub> ranges are available upon request.

### GENERAL DESCRIPTION

The ARC28F160A3FZ is a nonvolatile, electrically block-erasable (flash), programmable, read-only memory containing 16,777,216 bits organized as 1,048,576 words (16 bits).

The ARC28F160A3FZ is manufactured on 0.22µm process technology in a 48-ball FBGA package. The device

### BALL ASSIGNMENT (Top View) 48-Ball FBGA

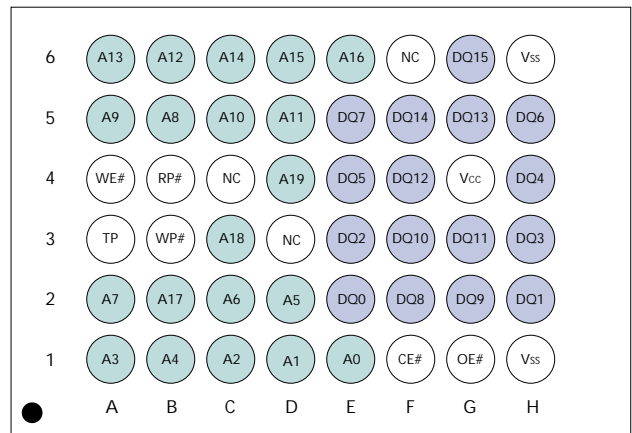

(Ball Down)

NOTE: NC contact balls are not internally connected.

has an I/O supply of 2.7V (MIN). Programming in production is accomplished by using high voltage which can be supplied on a separate line.

The embedded WORD WRITE and BLOCK ERASE functions are fully automated by an on-chip write state machine (WSM), which simplifies these operations and relieves the system processor of secondary tasks. The WSM status can be monitored by an on-chip status register to determine the progress of program/erase tasks.

# 16 Mbit (x16) Enhanced Boot Block Flash Memory

Figure 1  
Diagram of Internal and External Connections

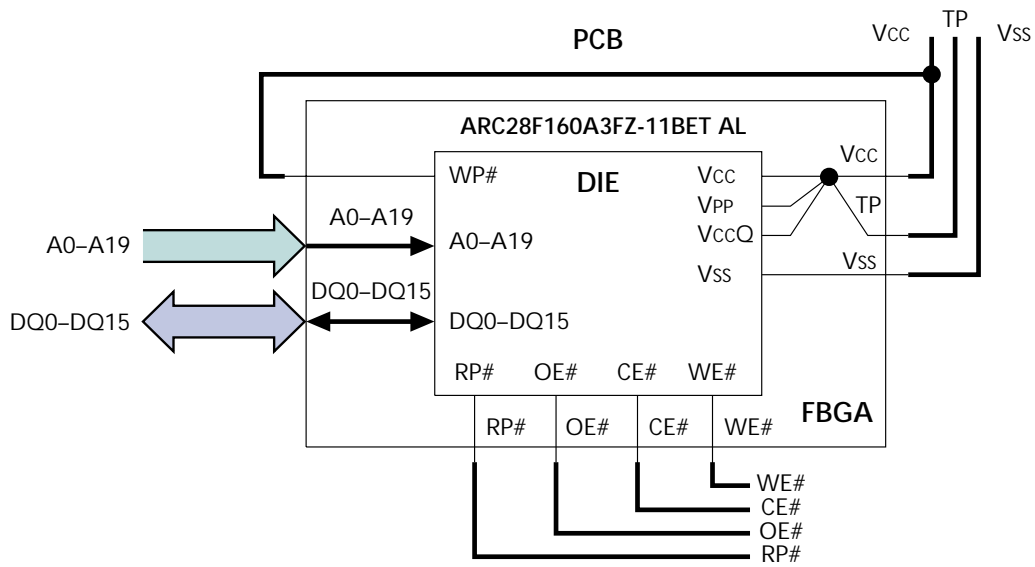

# **16 Mbit (x16) Enhanced Boot Block Flash Memory**

## BALL DESCRIPTIONS

46-BALL FBGA NUMBERS	SYMBOL	TYPE	DESCRIPTION
3B	WE#	Input	Write Enable: Determines if a given cycle is a WRITE cycle. If WE# is LOW, the cycle is either a WRITE to the command state machine (CSM) or to the memory array.
5A	WP#	Input	Write Protect: Unlocks the soft-protected blocks when HIGH if $V_{PP} = 2.7V-3.3V$ or $5V$ (WRITE only) and $RP# = V_{IH}$ for WRITE or ERASE. Does not affect WRITE or ERASE operation on other blocks.
7D	CE#	Input	Chip Enable: Activates the device when LOW. When CE# is HIGH, the device is disabled and goes into standby power mode.
4B	RP#	Input	Reset/Power-Down: When LOW, RP# clears the status register, sets the write state machine (WSM) to the array read mode and places the device in deep power-down mode. All inputs, including CE#, are "Don't Care," and all outputs are High-Z. RP# must be held at $V_{IH}$ during all other modes of operation.
8F	OE#	Input	Output Enable: Enables data output buffers when LOW. When OE# is HIGH, the output buffers are disabled.
1A, 1B, 1C, 1D, 2A, 2B, 2C, 3A, 3C, 5B, 6A, 6B, 6C, 7A, 7B, 7C, 8A, 8B, 8C, 8D	A0-A19	Input	Address Inputs: These address inputs select a unique, 16-bit word out of the 1,048,576 available.
2D, 2E, 2F, 3D, 3E, 3F, 4D, 4E, 4F, 5D, 5E, 6D, 6E, 6F, 7E, 7F	DQ0-DQ15	Input/Output	Data I/O: These data I/O are data output lines during any READ operation or data input lines during a WRITE. Data I/O are used to input commands to the CSM.
4A	$V_{PP}$	Supply	Write/Erase Supply Voltage: From a WRITE or ERASE CONFIRM until completion of the operation, $V_{PP}$ must be $2.7V-3.3V$ or $5V$ (WRITE only). $V_{PP} =$ "Don't Care" during all other operations.
5F	$V_{CC}$	Supply	Power Supply: $2.7V-3.3V$ .
1E	$V_{CCQ}$	Supply	I/O Supply Voltage: $2.7V-3.3V$ .
1F, 8E	$V_{SS}$	Supply	Ground.

# 16 Mbit (x16) Enhanced Boot Block Flash Memory

## TRUTH TABLE<sup>1</sup>

FUNCTION	RP#	CE#	OE#	WE#	WP#	V <sub>PP</sub>	A0	DQ0-DQ7	DQ8-DQ15
Standby	H	H	X	X	X	X	X	High-Z	High-Z
RESET	L	X	X	X	X	X	X	High-Z	High-Z
<b>READING</b>									
READ	H	L	L	H	X	X	X	Data-Out	Data-Out
Output Disable	H	L	H	H	X	X	X	High-Z	High-Z
<b>WRITE/ERASE (EXCEPT SOFT PROTECTED BLOCKS)<sup>2</sup></b>									
ERASE SETUP	H	L	H	L	X	X	X	20H	X
ERASE CONFIRM <sup>3</sup>	H	L	H	L	X	V <sub>PPH</sub>	X	D0H	X
WRITE SETUP	H	L	H	L	X	X	X	10H/40H	X
WRITE <sup>4</sup>	H	L	H	L	X	V <sub>PPH</sub>	X	Data-In	Data-In
READ ARRAY <sup>5</sup>	H	L	H	L	X	X	X	FFH	X
<b>WRITE/ERASE (SOFT-PROTECTED BLOCKS)<sup>2</sup></b>									
ERASE SETUP	H	L	H	L	X	X	X	20H	X
ERASE CONFIRM <sup>3</sup>	H	L	H	L	H	V <sub>PPH</sub>	X	D0H	X
WRITE SETUP	H	L	H	L	X	X	X	10H/40H	X
WRITE <sup>4</sup>	H	L	H	L	H	V <sub>PPH</sub>	X	Data-In	Data-In
READ ARRAY <sup>5</sup>	H	L	H	L	X	X	X	FFH	X
<b>DEVICE IDENTIFICATION<sup>6</sup></b>									
Manufacturer	H	L	L	H	X	X	L	2CH	00H
Device (top boot)	H	L	L	H	X	X	H	92H	44H
Device (bottom boot)	H	L	L	H	X	X	H	93H	44H

- NOTE:**
1. L = V<sub>IL</sub> (LOW), H = V<sub>IH</sub> (HIGH), X = V<sub>IL</sub> or V<sub>IH</sub> ("Don't Care").
  2. V<sub>PPH1</sub> = 2.7V-3.3V for ERASE, and V<sub>PPH2</sub> = 2.7V-3.3V or 5V for WRITE.
  3. Operation must be preceded by ERASE SETUP command.
  4. Operation must be preceded by WRITE SETUP command.
  5. The READ ARRAY command must be issued before reading the array after writing or erasing.
  6. See Table 3 for the IDENTIFY DEVICE command.

# 16 Mbit (x16) Enhanced Boot Block Flash Memory

Figure 2  
Bottom Boot Block Memory Address Map

ADDRESS RANGE

FFFFh		
F8000h	32K-Word Block	31
F7FFFh		
F0000h	32K-Word Block	30
EFFFFh		
E8000h	32K-Word Block	29
E7FFFh		
E0000h	32K-Word Block	28
DFFFFh		
D8000h	32K-Word Block	27
D7FFFh		
D0000h	32K-Word Block	26
CFFFFh		
C8000h	32K-Word Block	25
C7FFFh		
C0000h	32K-Word Block	24
BFFFFh		
B8000h	32K-Word Block	23
B7FFFh		
B0000h	32K-Word Block	22
AFFFFh		
A8000h	32K-Word Block	21
A7FFFh		
A0000h	32K-Word Block	20
9FFFFh		
98000h	32K-Word Block	19
97FFFh		
90000h	32K-Word Block	18
8FFFFh		
88000h	32K-Word Block	17
87FFFh		
80000h	32K-Word Block	16
7FFFFh		
78000h	32K-Word Block	15
77FFFh		
70000h	32K-Word Block	14
6FFFFh		
68000h	32K-Word Block	13
67FFFh		
60000h	32K-Word Block	12
5FFFFh		
58000h	32K-Word Block	11
57FFFh		
50000h	32K-Word Block	10
4FFFFh		
48000h	32K-Word Block	9
47FFFh		
40000h	32K-Word Block	8
3FFFFh		
38000h	32K-Word Block	7
37FFFh		
30000h	32K-Word Block	6
2FFFFh		
28000h	32K-Word Block	5
27FFFh		
20000h	32K-Word Block	4
1FFFFh		
18000h	32K-Word Block	3
17FFFh		
10000h	32K-Word Block	2
0FFFFh		
08000h	32K-Word Block	1
07FFFh		
00000h	8 x 4K-Word Blocks	0

 Boot Blocks

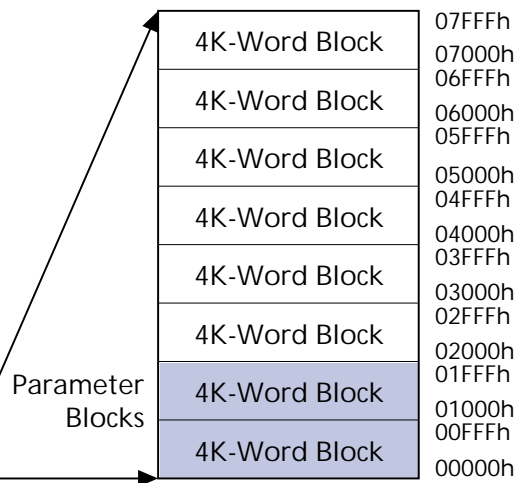

NOTE: 1. The two 4K-word blocks (boot blocks) can only be locked/unlocked by WP#.

# 16 Mbit (x16) Enhanced Boot Block Flash Memory

## MEMORY ORGANIZATION

The ARC28F160A3FZ memory array is segmented into 31 blocks of 32K words, along with eight 4K-word parameter blocks. The device is available with block architecture mapped in either of the two configurations: the parameter blocks located at the top or at the bottom of the memory array, as required by different microprocessors. The ARC28F160A3FZ top boot configuration with the blocks and address ranges is shown in Figure 1 and the bottom boot configuration in Figure 2.

The boot blocks are used to store key system data and are seldom changed during normal operation. When the WP# is at VIL, the contents of the boot block cannot be erase or reprogrammed. The boot block contents can be changed only through proper command sequences when WP# is HIGH.

## COMMAND STATE MACHINE

Commands are issued to the command state machine (CSM) using standard microprocessor write timings. The CSM acts as an interface between the external microprocessor and the internal write state machine (WSM). The available commands are listed in Table 2, and the descriptions of these commands are shown in Table 3. Program and erase algorithms are automated by an on-chip WSM. Once a valid program/erase command sequence is entered, the WSM executes the appropriate algorithm, which generates the necessary timing signals to control the device internally to accomplish the requested operation. A command is valid only if the exact sequence of WRITES is completed. After the WSM completes its task, the WSM status bit (SR7) is set to a logic HIGH level (1), allowing the CSM to respond to the full command set again.

## OPERATION

Device operations are selected by entering standard JEDEC 8-bit command codes with conventional microprocessor timings into an on-chip CSM through I/Os DQ0-DQ7. When the device is powered up, internal reset

circuitry initializes the chip to a read array mode of operation. Changing the mode of operation requires that a command code be entered into the CSM. The on-chip status register allows the progress of various operations to be monitored. The status register is interrogated by entering a READ STATUS REGISTER command onto the CSM (cycle 1) and reading the register data on I/Os DQ0-DQ7 (cycle 2). Status register bits SR0-SR7 correspond to DQ0-DQ7 (see Table 3).

**Table 2**  
**Command State Machine Codes for Device Mode Selection**

COMMAND DQ0-DQ7	CODE ON DEVICE MODE
10h/40h	Write setup/alternate write setup
20h	Block erase setup
50h	Clear status register
70h	Read status register
90h	Identify device
B0h	Program/erase suspend
FFh	Read array
D0h	Program/erase resume Erase confirm
FFh	Read array
60h, 0Fh, AFh	Reserved

# 16 Mbit (x16) Enhanced Boot Block Flash Memory

## COMMAND DEFINITIONS

Once a specific command code has been entered, the WSM executes an internal algorithm generating the necessary timing signals to program, erase, and verify data.

See Table 3 for the CSM command definitions and data for each of the bus cycles.

Table 3  
Command Definitions

COMMAND	FIRST CYCLE			SECOND CYCLE		
	OPERATION	ADDRESS	CSM/INPUT	OPERATION	ADDRESS	DATA
READ ARRAY	WRITE	X	FFh	READ	WA	AD
IDENTIFY DEVICE	WRITE	X	90h	READ	IA	ID
READ STATUS REGISTER	WRITE	X	70h	READ	BA	SRD
WORD PROGRAM	WRITE	X	10h/40h	WRITE	WA	PD
BLOCK ERASE	WRITE	X	20h	WRITE	BA	D0h
PROGRAM/ERASE SUSPEND	WRITE	X	B0h			
PROGRAM/ERASE RESUME	WRITE	X	D0h			
CLEAR STATUS REGISTER	WRITE	X	50h			

- NOTE:**
1. The command data is written through DQ0-DQ7
  2. ID = Manufacturer ID: 002Ch; Device ID (Top Boot): 4490h; Device ID (Bottom Boot): 4491h
  3. IA = Identify address: 00000h for manufacturer code and 00001h for device code
  4. BA = Any address within the block to be selected
  5. WA = Word address
  6. AD = Array data
  7. SRD = Data read from status register
  8. PD = Data to be written at location WA
  9. X = Don't Care

# 16 Mbit (x16) Enhanced Boot Block Flash Memory

## STATUS REGISTER

The status register allows the user to determine whether the state of a PROGRAM/ERASE operation is pending or complete. The status register is monitored by toggling OE# and CE# and by reading the resulting status code on I/Os DQ0-DQ7. The high-order I/Os (DQ8-DQ15) are set to 00h internally, so only the low-order I/Os (DQ0-DQ7) need interpreting.

Register data is updated on the falling edge of OE# or CE#. The latest falling edge of either of these two signals updates the latch within a given READ cycle. Latching the data prevents errors from occurring if the register input changes during a status register monitoring. To ensure that the status register output contains updated status data, CE# or OE# must be toggled for each subsequent STATUS READ.

The status register provides the internal state of the WSM to the external microprocessor. During periods when the WSM is active, the status register can be polled to determine the WSM status. Table 4 defines the status register bits.

After monitoring the status register during a PROGRAM/ERASE, the data appearing on DQ0-DQ7 remains as status register data until a new command is issued to the CSM. To return the device to other modes of operation, a new command must be issued to the CSM.

## COMMAND STATE MACHINE OPERATIONS

The CSM decodes instructions for read, read device identification code, read status register, clear status register, program, erase, erase suspend, erase resume, program suspend, program resume. The 8-bit command code is input to the device on DQ0-DQ7 (see Table for CSM codes). During a PROGRAM or ERASE cycle, the CSM informs the WSM that a PROGRAM or ERASE cycle has been requested.

During a PROGRAM cycle, the WSM controls the program sequences and the CSM responds to a PROGRAM SUSPEND command only. During an ERASE cycle, the CSM responds to an ERASE SUSPEND command only. When the WSM has completed its task, the WSM status bit (SR7) is set to a logic HIGH level and the CSM responds to the full command set. The CSM stays in the current command state until the microprocessor issues another command.

The WSM successfully initiates an ERASE or PROGRAM operation only when V<sub>PP</sub> is within its correct voltage range. For data protection, it is required that RP# be held at a logic LOW level during a CPU reset.

## CLEAR STATUS REGISTER

The WSM can set to "1" the block lock status bit (SR1), the V<sub>PP</sub> status bit (SR3), the program status bit (SR4), and the erase status bit (SR5) of the status register. The CLEAR STATUS REGISTER command (50h) allows the external microprocessor to clear these status bits and synchronize to internal operations. After issuing this command, the status bits are cleared and the device returns to the read array mode.

## READ OPERATIONS

Three READ operations are available: read array, read device identification code, and read status register.

### READ ARRAY

The array is read by entering the command code FFh on DQ0-DQ7. Control signals CE# and OE# must be at a logic LOW level (V<sub>IL</sub>) and WE# and RP# must be at a logic HIGH level (V<sub>IH</sub>) to read data from the array. Data is available on DQ0-DQ15. Any valid address within any of the blocks selects that address and allows data to be read from that address. Upon initial power-up, the device defaults to the read array mode.

### READ DEVICE IDENTIFICATION CODE

Device identification codes are read by entering command code 90h on DQ0-DQ7. Two bus cycles are required for this operation, the first to enter the command code and the second to read the selected code. Control signals CE# and OE# must be at a logic LOW level (V<sub>IL</sub>) and WE# and RP# must be at a logic HIGH level (V<sub>IH</sub>). The manufacturer code is obtained on DQ0-DQ15 in the second cycle, after the identify address 00000h is latched. The device code is obtained on DQ0-DQ15 in the second cycle, after the identify address 00001h is latched (see Table 3).

### READ STATUS REGISTER

The status register is read by entering the command code 70h on DQ0-DQ7. Control signals CE# and OE# must be at a logic LOW level (V<sub>IL</sub>), and WE# and RP# must be at a logic HIGH level (V<sub>IH</sub>). Two bus cycles are required for this operation: one to enter the command code, and one to read the status register. The status register contents are updated on the falling edge of CE# or OE#, whichever occurs last within the cycle.

# 16 Mbit (x16) Enhanced Boot Block Flash Memory

Table 4  
Status Register

STATUS BIT #	STATUS REGISTER BIT	DESCRIPTION
SR7	WRITE STATE MACHINE STATUS (WSM) 1 = Ready 0 = Busy	If SR7 = 0 (busy), the WSM has not completed an ERASE or PROGRAM operation. If SR7 = 1 (ready), other operations can be performed.
SR6	ERASE SUSPEND STATUS 1 = ERASE SUSPEND 0 = ERASE in progress or ERASE complete	If SR6 = 1, WSM halts execution, indicating that the ERASE operation has been suspended. SR6 remains "1" until an ERASE RESUME command is issued.
SR5	ERASE STATUS 1 = BLOCK ERASE error 0 = BLOCK ERASE successful	SR5 = 0 indicates that a BLOCK ERASE has been successful. SR5 = 1 indicates that an erase has failed; therefore, the WSM has completed the maximum allowable erase pulses determined by the internal algorithm but which were insufficient to completely erase the device.
SR4	PROGRAM STATUS 1 = PROGRAM error 0 = PROGRAM successful	SR4 = 0 indicates successful programming has occurred at the address location. SR4 = 1 indicates the WSM was unable to correctly program the addressed location.
SR3	V <sub>PP</sub> STATUS 1 = Program abort V <sub>PP</sub> range error 0 = V <sub>PP</sub> good	SR3 provides status of V <sub>PP</sub> during programming.
SR2	PROGRAM SUSPEND STATUS 1 = PROGRAM suspended 0 = PROGRAM in progress or PROGRAM complete	If SR2 = 1, WSM halts execution, indicating the PROGRAM operation has been suspended. SR2 stays "1" until a PROGRAM RESUME command is issued.
SR1	BLOCK LOCK STATUS 1 = Block locked 0 = Block not locked	SR1 = 1 indicates that the address block is locked when WP# = V <sub>IL</sub> . Any attempt to program/erase this block will abort the operation and the device will return to read status mode.
SR0	RESERVED	

- NOTE:**
- After a PROGRAM/ERASE command is issued and confirmed, status bit SR7 goes LOW to indicate that the operation is in progress. If SR7 = 1 (ready), other polling operations can be performed. Until this occurs, the other status bits are not valid. SR7 is not updated automatically at the completion of a WSM task; therefore, if the WSM status bit shows busy (0), OE# and CE# must be toggled periodically to determine when the WSM has completed an operation (SR7 = 1).
  - When an ERASE SUSPEND command is issued, the WSM halts execution and sets SR6 = 1, indicating that the ERASE operation has been suspended. The WSM status bit is also set to HIGH (SR7 = 1), indicating that the ERASE SUSPEND operation has been completed successfully.
  - During an ERASE error, the SR5 bit is set (SR5 = 1), while SR5 = 0 indicates that a successful block erasure has occurred.
  - If the WSM is unable to program the addressed location correctly, the SR4 bit is set (SR4 = 1) and SR4 = 0 indicates that a successful programming operation has occurred at the addressed block location. Information concerning the status of V<sub>PP</sub> during programming/erasure is provided by SR3. If V<sub>PP</sub> is lower than V<sub>PLK</sub> after a PROGRAM/ERASE command has been issued, SR3 is set to a "1," indicating that the PROGRAM/ERASE operation has aborted due to a low V<sub>PP</sub>.
  - During a PROGRAM SUSPEND command, the WSM halts execution and the SR2 bit is set, indicating that the PROGRAM operation has been suspended. This bit remains "1" until a PROGRAM RESUME command is issued. The WSM status bit is also set to HIGH (SR7 = 1), indicating that the PROGRAM SUSPEND operation has been completed successfully.
  - A proper block address must be provided in an ERASE operation. If that addressed block is protected, then the SR1 bit is set (SR1 = 1) when WP# = V<sub>IL</sub>. If that block is not protected, then SR1 = 0.

# 16 Mbit (x16) Enhanced Boot Block Flash Memory

## PROGRAMMING OPERATIONS

There are two CSM commands for programming: program setup and alternate program setup (see Table 2). After the desired command code is entered, the WSM takes over and correctly sequences the device to complete the program operation. Monitoring of the WRITE operation is possible through the status register (see the Status Register section). During this time, the CSM responds only to a PROGRAM SUSPEND command until the PROGRAM operation has been completed, after which all commands to the CSM become valid again. (See Figure 4 for programming operation.)

During programming,  $V_{PP}$  must remain in the appropriate  $V_{PP}$  voltage range as shown in the recommended operating conditions table. Different combinations of RP#, WP#, and  $V_{PP}$  voltage levels ensure that data in certain blocks are secure and therefore cannot be programmed (see Table 5 for a list of combinations). Only "0s" are written and compared during a PROGRAM operation. If "1s" are programmed, the memory cell contents do not change and no error occurs.

## PROGRAM SUSPENSION

The PROGRAM operation can be suspended by issuing a PROGRAM SUSPEND command (B0h). The PROGRAM SUSPEND command typically takes 1 $\mu$ s to execute, and the device is then in program suspend mode. Once the WSM has reached the suspend state, it allows the CSM to respond only to READ ARRAY, READ STATUS REGISTER, and PROGRAM RESUME commands. During the PROGRAM SUSPEND operation, array data should be read from an address other than the one being programmed. To resume the PROGRAM operation, a PROGRAM RESUME command (D0h) must be issued to cause the CSM to clear the suspend state previously set. (See Figure 7 for PROGRAM SUSPEND and PROGRAM RESUME.)

## ERASE OPERATIONS

An ERASE operation must be used to initialize all bits in an array block to "1s." After BLOCK ERASE CONFIRM is issued, the CSM responds only to an ERASE SUSPEND command until the WSM completes its task.

Block erasure inside the memory array sets all bits within the addressed block to logic 1s. Erase is accomplished only by blocks; data at single address locations within the array cannot be erased individually. The block to be erased is selected by using any valid address within that block. Note that different combinations of RP#, WP# and  $V_{PP}$  voltage levels ensure that data in certain blocks are secure and therefore cannot be erased (see Table 5 for a list of combinations). Block erasure is initiated by a command sequence to the CSM: block erase setup (20h) followed by block erase confirm (D0h) (see Figure 5). A two-command erase sequence protects against accidental erasure of memory contents.

When the BLOCK ERASE CONFIRM command is complete, the WSM automatically executes a sequence of events to complete the block erasure. During this sequence, the block is programmed with logic 0s, data is verified, all bits in the block are erased, and finally verification is performed to ensure that all bits are correctly erased. Monitoring of the ERASE operation is possible through the status register (see the Status Register section).

## ERASE SUSPENSION

During the execution of an ERASE operation, the ERASE SUSPEND command (B0h) can be entered to direct the WSM to suspend the ERASE operation. The ERASE SUSPEND command typically takes 1 $\mu$ s to execute, and the device is then in erase suspend mode. Once the WSM has reached the suspend state, it allows the CSM to respond only to the READ ARRAY, READ STATUS REGISTER, ERASE RESUME and PROGRAM commands. Dur-

Table 5  
Data Protection Combinations

DATA PROTECTION PROVIDED	$V_{PP}$	RP#	WP#
All blocks locked	$\leq V_{PPLK}$	X	X
All blocks locked	X	$V_{IL}$	X
All blocks unlocked	$\geq V_{PPLK}$	$V_{IH}$	$V_{IH}$
Soft-protected blocks locked	$\geq V_{PPLK}$	$V_{IH}$	$V_{IL}$

## 16 Mbit (x16) Enhanced Boot Block Flash Memory

ing the ERASE SUSPEND operation, array data must be read from a block other than the one being erased. To resume the ERASE operation, an ERASE RESUME command (D0h) must be issued to cause the CSM to clear the suspend state previously set. It is also possible that an ERASE in any block can be suspended and a WRITE to another block can be initiated. After the completion of WRITE, the ERASE can be resumed by writing an ERASE RESUME command (see Figure 5). It is also possible to suspend the WRITE operation and read from another block.

### AUTOMATIC POWER-SAVING MODE

Substantial power savings are realized during periods when the device is not accessed while in the active mode. During this time, the device switches to the automatic power saving (APS) mode. When the device switches to this mode,  $I_{cc}$  is reduced to  $1\mu A$  typically. This mode is entered automatically if no address or control lines toggle within approximately a 300ns time-out period. At least one transition on CE# must occur after power-up to activate this mode's availability. The device remains in this mode and the I/O lines retain the data from the last access until a new read address is issued or another operation is initiated.

### RESET/ DEEP POWER-DOWN MODE

Very low levels of power consumption can be attained by using a special ball, RP#, to disable internal device circuitry. When RP# is at a logic LOW level of  $0.0V \pm 0.2V$ , a much lower  $I_{cc}$  current consumption is achieved, typically  $1\mu A$ . This is important in portable applications where extended battery life is a major concern.

A recovery time is required when exiting from deep power-down mode. A minimum of  $t_{RS}$  is required before a CSM command can be recognized. With RP# at ground, the WSM is reset and the status register is cleared, effectively eliminating accidental programming to the array during system reset. After restoration of power, the device will be disabled until RP# is returned to  $V_{IH}$ .

If RP# goes LOW during a PROGRAM or ERASE operation, the device powers down and becomes nonfunctional. Data being written or erased at that time becomes

invalid or indeterminate, requiring that the operation be performed again after power restoration. When RP# is set at logic LOW, all internal circuits will be reset. Setting RP# LOW during a PROGRAM or ERASE operation is not recommended.

### STANDBY MODE

$I_{cc}$  supply current is reduced by applying a logic HIGH level on CE# and RP# to enter the standby mode. In the standby mode, the outputs are placed in the high-impedance state. Applying a logic HIGH level ( $V_{CCQ}$ ) on CE# and RP# reduces the current to  $1\mu A$  typically. If the device is deselected during an ERASE operation or during programming, the device continues to draw active current until the operation is complete.

### BOOT BLOCK DATA PROTECTION

The WP# must be LOW for the locking mechanism to work. The only way to unlock boot blocks is to force the WP# signal HIGH. When WP# is LOW, the boot blocks are locked once again (see Table 5).

### POWER-UP

During a power-up, it is not necessary to sequence  $V_{CCQ}$ ,  $V_{CC}$  and  $V_{PP}$ . However, it is recommended that RP# be held LOW during power-up for additional protection while  $V_{CC}$  is ramping above  $V_{LKO}$  to a stable operative level. After a power-up or RESET, the status register is reset, and the device will enter the array read mode.

### POWER-UP PROTECTION

The likelihood of unwanted WRITE or ERASE operations is minimized since two consecutive cycles are required to execute either operation. When  $V_{CC} < V_{LKO}$ , the device does not accept any WRITE cycles, and noise pulses  $< 5ns$  on CE# or WE# do not initiate a WRITE cycle.

### POWER SUPPLY DECOUPLING

For decoupling purposes, each device should have a  $0.1\mu F$  ceramic capacitor connected between  $V_{CC}$  and  $V_{SS}$ ,  $V_{PP}$  and  $V_{SS}$ , and between  $V_{CCQ}$  and  $V_{SS}$ . The capacitor should be as close as possible to the device balls.

# 16 Mbit (x16) Enhanced Boot Block Flash Memory

**Figure 3**  
**Automated Word Programming**  
**Flowchart**

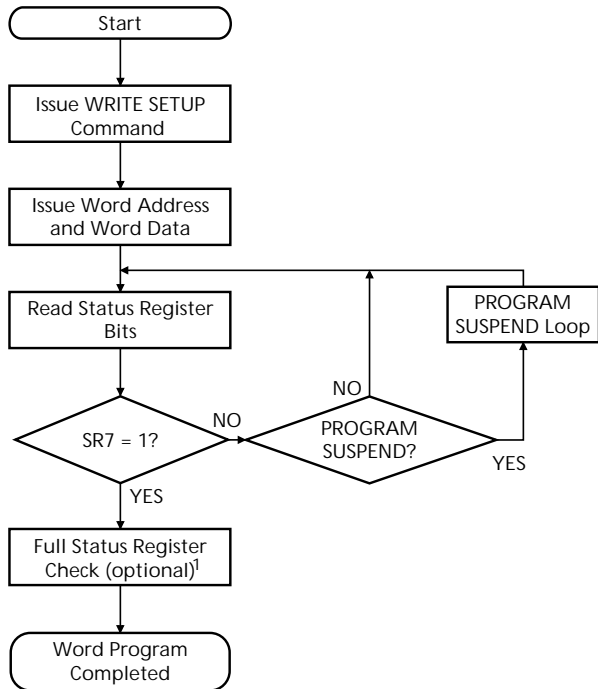

BUS OPERATION	COMMAND	COMMENTS
WRITE	WRITE SETUP	Data = 40h or 10h Addr = Don't Care
WRITE	WRITE DATA	Data = Word to be programmed Addr = Address of word to be programmed
READ		Status register data Toggle OE# or CE# to update status register.
Standby		Check SR7 1 = Ready, 0 = Busy
Repeat for subsequent words. Write FFh after the last word programming operation to reset the device to read array mode.		

**FULL STATUS REGISTER CHECK FLOW**

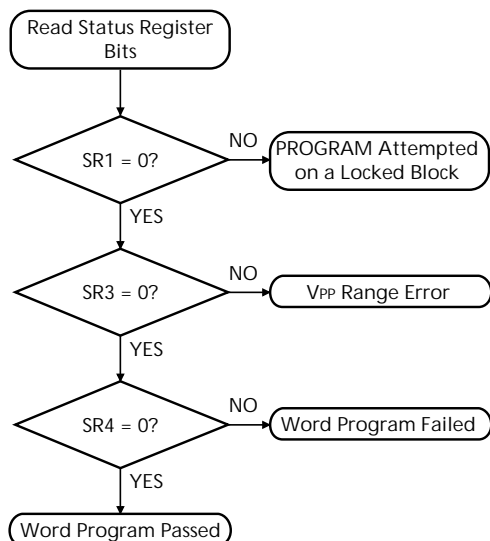

BUS OPERATION	COMMAND	COMMENTS
Standby		Check SR1 1 = Detect locked block
Standby		Check SR3 <sup>2</sup> 1 = Detect V <sub>PP</sub> low
Standby		Check SR4 <sup>3</sup> 1 = Word program error

- NOTE:**
1. Full status register check can be done after each word or after a sequence of words.
  2. SR3 must be cleared before attempting additional PROGRAM/ERASE operations.
  3. SR4 is cleared only by the CLEAR STATUS REGISTER command, but it does not prevent additional program operation attempts.

# 16 Mbit (x16) 3V Enhanced+Boot Block Flash Memory

Figure 4  
Automated BLOCK ERASE Flowchart

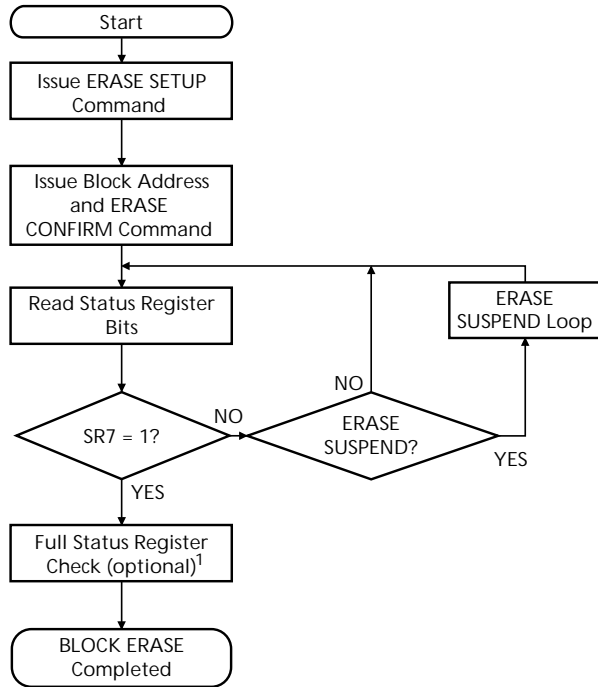

BUS OPERATION	COMMAND	COMMENTS
WRITE	WRITE ERASE SETUP	Data = 20h Addr = Don't Care
WRITE	ERASE	Data = D0h Block Addr = Address within block to be erased
READ		Status register data Toggle OE# or CE# to update status register.
Standby		Check SR7 1 = Ready, 0 = Busy
Repeat for subsequent blocks. Write FFh after the last BLOCK ERASE operation to reset the device to read array mode.		

FULL STATUS REGISTER CHECK FLOW

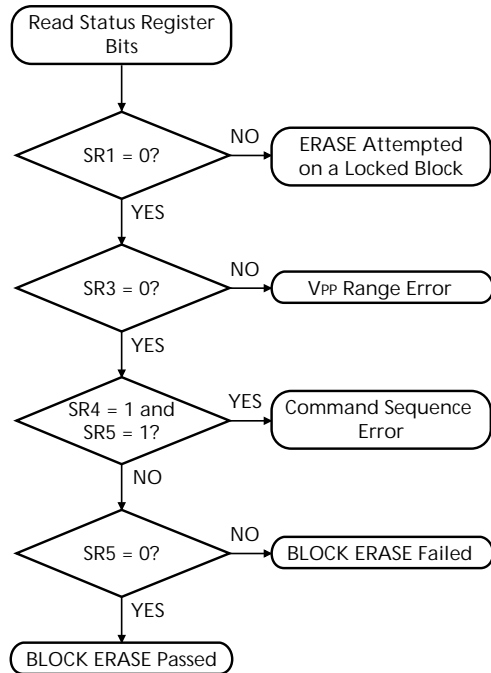

BUS OPERATION	COMMAND	COMMENTS
Standby		Check SR1 1 = Detect locked block
Standby		Check SR3 <sup>2</sup> 1 = Detect V <sub>PP</sub> low
Standby		Check SR4 and SR5 1 = BLOCK ERASE command error
Standby		Check SR5 <sup>3</sup> 1 = BLOCK ERASE error

- NOTE: 1. Full status register check can be done after each block or after a sequence of blocks.  
 2. SR3 must be cleared before attempting additional PROGRAM/ERASE operations.  
 3. SR5 is cleared only by the CLEAR STATUS REGISTER command in cases where multiple blocks are erased before full status is checked.

# 16 Mbit (x16) Enhanced Boot Block Flash Memory

Figure 5  
ERASE SUSPEND/ERASE RESUME  
Flowchart

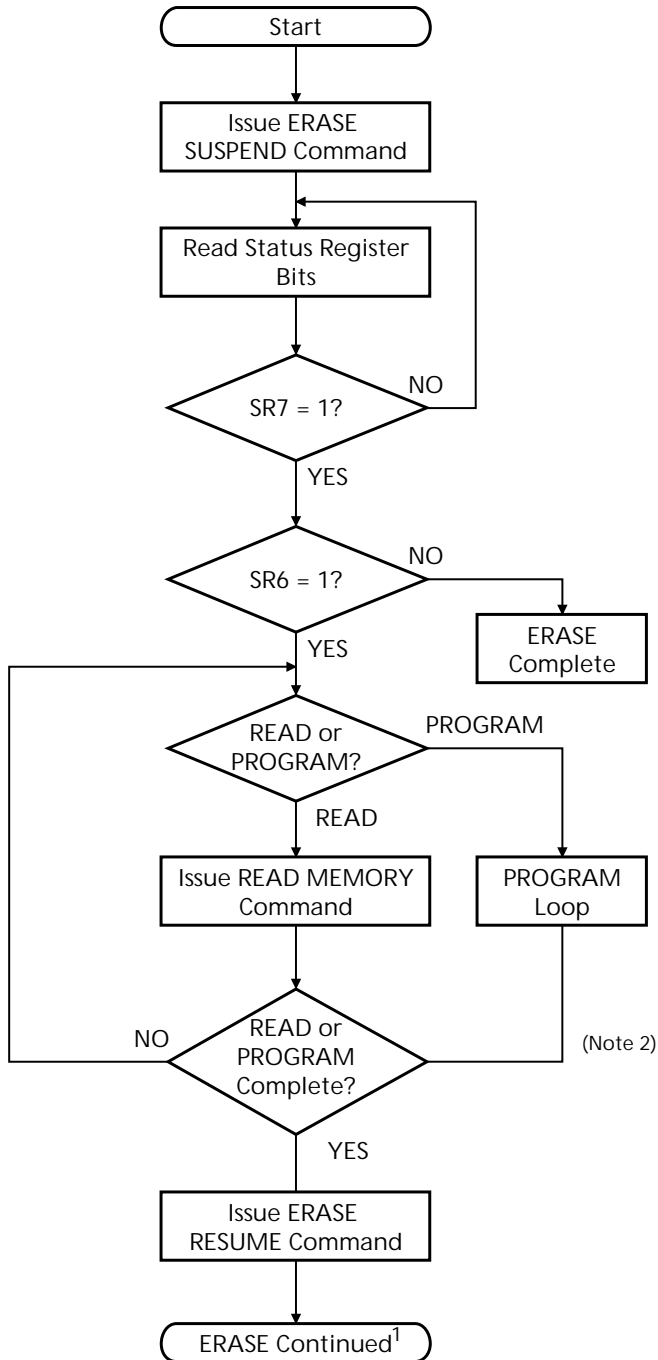

BUS OPERATION	COMMAND	COMMENTS
WRITE	ERASE SUSPEND	Data = B0h
READ		Status register data Toggle OE# or CE# to update status register
Standby		Check SR7 1 = Ready
Standby		Check SR6 1 = Suspended
WRITE or WRITE	READ MEMORY WRITE SETUP	Data = FFh Data = 40h or 10h Addr = Don't Care
READ or WRITE	WRITE DATA	Read data from block other than that being erased Data = Word to be programmed Addr = Address of word to be programmed
WRITE	ERASE RESUME	Data = D0h Addr = Don't Care

NOTE: 1. See BLOCK ERASE Flowchart for complete erasure procedure.  
2. See Word Programming Flowchart for complete programming procedure.

# 16 Mbit (x16) Enhanced Boot Block Flash Memory

Figure 6  
PROGRAM SUSPEND/  
PROGRAM RESUME Flowchart

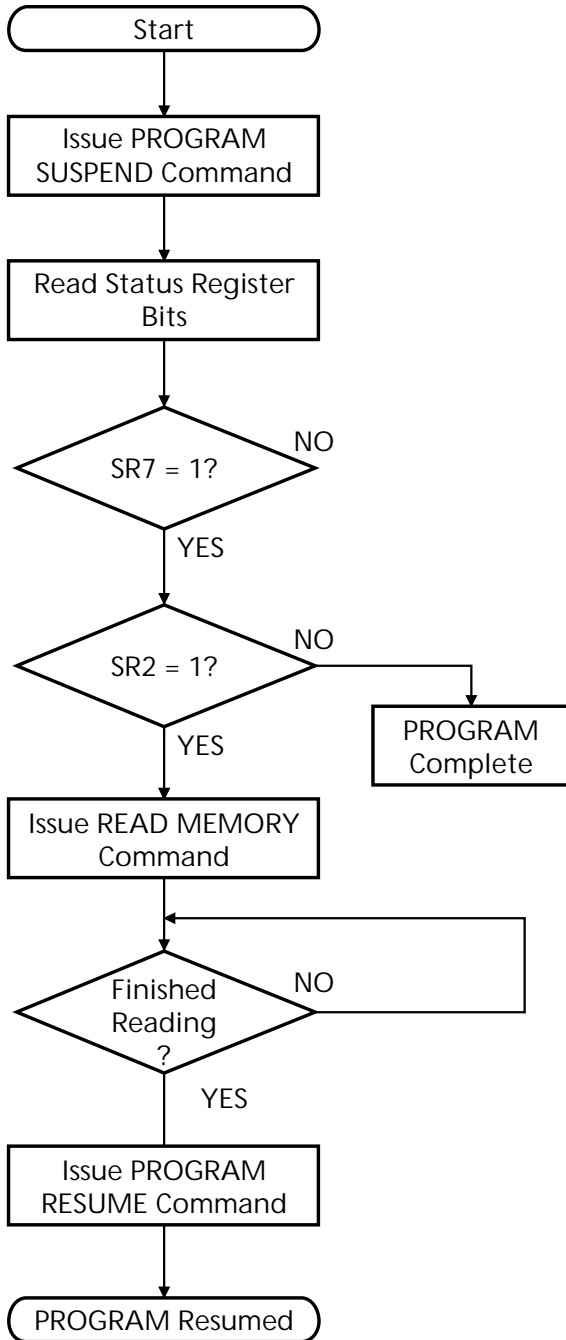

BUS OPERATION	COMMAND	COMMENTS
WRITE	PROGRAM SUSPEND	Data = B0h
READ		Status register data Toggle OE# or CE# to update status register
Standby		Check SR7 1 = Ready
Standby		Check SR2 1 = Suspended
WRITE	READ MEMORY	Data = FFh
READ		Read data from block other than that being programmed
WRITE	PROGRAM RESUME	Data = D0h Addr = Don't Care

# 16 Mbit (x16) Enhanced Boot Block Flash Memory

## ABSOLUTE MAXIMUM RATINGS<sup>1, 2</sup>

Supply Voltage Range, $V_{CC}$ .....	-0.6V to +4.0V <sup>3</sup>
Supply Voltage Range, $V_{PP}$ .....	-0.6V to +6.0V <sup>3</sup>
Input Voltage Range .....	-0.6V to +4.0V
Output Voltage Range .....	-0.6V to +4.0V <sup>4</sup>
Storage Temperature Range, $T_{STG}$ .....	-65°C to +150°C

<sup>1</sup>Stresses greater than those listed under "Absolute Maximum Ratings" may cause permanent damage to the device. This is a stress rating only, and functional operation of the device at these or any other conditions above those indicated in the operational sections of this specification is not implied. Exposure to absolute maximum rating conditions for extended periods may affect reliability.

<sup>2</sup>All voltage values are with respect to  $V_{SS}$ .

<sup>3</sup>The voltage can undershoot to -1V for periods < 20ns.

<sup>4</sup>The voltage on any output can overshoot to 4.6V for periods < 20ns.

## ELECTRICAL CHARACTERISTICS AND RECOMMENDED DC OPERATING CONDITIONS

(-40°C ≤  $T_A$  ≤ +85°C)

PARAMETER/CONDITION	SYMBOL	MIN	MAX	UNITS	NOTES
Supply Voltage (during program/read/erase/suspend)	$V_{CC}$	2.7	3.3	V	5
I/O Supply Voltage	$V_{CCQ}$	2.7	3.3	V	5, 6
Supply Voltage (during program/erase operations)	$V_{PP1}$	2.7	3.3	V	5
	$V_{PP2}$	5	5.5	V	5, 7
Input High (Logic 1) Voltage, all inputs	$V_{IH}$	$V_{CCQ} - 0.2$	$V_{CCQ} + 0.2$	V	5
Input Low (Logic 0) Voltage, all inputs	$V_{IL}$	-0.2	0.2	V	5
OUTPUT VOLTAGE LEVELS $V_{CC} = V_{CC} (MIN)$ , $V_{CCQ} = V_{CCQ} (MIN)$	$V_{OH}$	$V_{CCQ} - 0.1$	-	V	5
Output High Voltage ( $I_{OH} = -0.1mA$ )	$V_{OL}$	-	0.1	V	
Output Low Voltage ( $I_{OL} = 0.1mA$ )					
INPUT LEAKAGE CURRENT $V_{CC} = V_{CC} (MAX)$ , $V_{CCQ} = V_{CCQ} (MAX)$ Any input ( $0V \leq V_{IN} \leq V_{CCQ}$ ); All other balls not under test = 0V	$I_L$	-1	1	μA	
OUTPUT LEAKAGE CURRENT $V_{CC} = V_{CC} (MAX)$ , $V_{CCQ} = V_{CCQ} (MAX)$ ( $D_{OUT}$ is disabled; $0V \leq V_{OUT} \leq V_{CCQ}$ )	$I_{OZ}$	-10	10	μA	
BLOCK ERASE cycling	-	100K	-	Cyc	

NOTE: 5. All voltages referenced to  $V_{SS}$ .

6.  $V_{CCQ}$  must be less than or equal to  $V_{CC}$ .

7. 5V  $V_{PP}$  is allowable for production programming only, not erasing.

# 16 Mbit (x16) Enhanced Boot Block Flash Memory

## CAPACITANCE

( $T_A = +25^\circ\text{C}$ ;  $f = 1\text{ MHz}$ )

PARAMETER/CONDITION	SYMBOL	MAX	UNITS	NOTES
Input Capacitance	$C_i$	8	pF	
Output Capacitance	$C_o$	12	pF	

## READ, STANDBY AND DEEP POWER-DOWN CURRENT DRAIN

( $-40^\circ\text{C} \leq T_A \leq +85^\circ\text{C}$ ;  $V_{CC} = 2.7\text{V}-3.3\text{V}$ )

PARAMETER/CONDITION	SYMBOL	TYP	MAX	UNITS	NOTES
READ CURRENT: $V_{CC} = V_{CC}(\text{MAX})$ , $V_{CCQ} = V_{CCQ}(\text{MAX})$ ( $CE\# = V_{IL}$ ; $OE\# = V_{IH}$ ; $RP\# = V_{IH}$ ; $f = 5\text{ MHz}$ ; Other inputs $V_{IH}$ or $V_{IL}$ )	$I_{CC1}$	-	20	mA	1, 2
STANDBY CURRENT: $V_{CC}$ SUPPLY $V_{CC} = V_{CC}(\text{MAX})$ ; ( $CE\# = RP\# = V_{CCQ}$ )	$I_{CC2}$	1	10	$\mu\text{A}$	
DEEP POWER-DOWN CURRENT: $V_{CC}$ SUPPLY $V_{CC} = V_{CC}(\text{MAX})$ ; $V_{CCQ} = V_{CCQ}(\text{MAX})$ ( $RP\# = V_{IL}$ ; Other inputs $V_{CCQ}$ or $V_{SS}$ )	$I_{CC3}$	1	10	$\mu\text{A}$	
READ CURRENT: $V_{PP}$ SUPPLY	$V_{PP} \leq V_{CC}$	$I_{PP1}$	2	$\pm 15$	$\mu\text{A}$
	$V_{PP} > V_{CC}$	$I_{PP2}$	50	200	$\mu\text{A}$
DEEP POWER-DOWN CURRENT: $V_{PP}$ SUPPLY ( $RP\# = V_{IL}$ ; $V_{PP} \leq V_{CC}$ )	$I_{PP3}$	1	10	$\mu\text{A}$	

NOTE: 1.  $I_{CC}$  is dependent on cycle rates.  
2. Automatic power savings (APS) mode reduces  $I_{CC1}$  to standby current level  $I_{CC2}$  for static operation.

# 16 Mbit (x16) Enhanced Boot Block Flash Memory

## AC TEST CONDITIONS

Input pulse levels .....	0V to $V_{CCQ}$
Input rise and fall times .....	<10ns
Input timing reference level .....	$V_{CCQ}/2$
Output timing reference level .....	$V_{CCQ}/2$
Output load .....	$C_L = 30\text{pF}$

**Figure 8**  
AC Test Output and Load Circuit

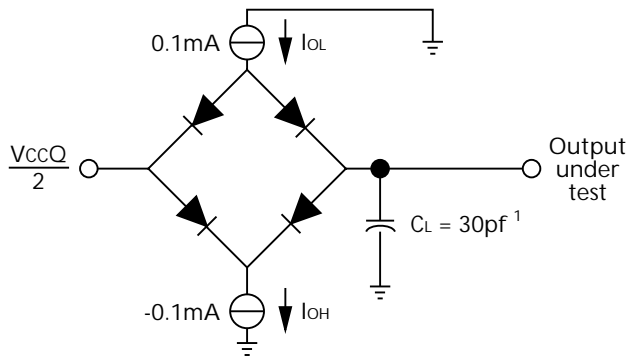

**Figure 9**  
AC Input/Output Reference Waveform

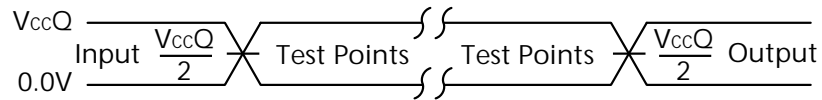

NOTE: 1.  $C_L$  includes probe and fixture capacitance.

# 16 Mbit (x16) Enhanced Boot Block Flash Memory

## READ AC TIMING CHARACTERISTICS AND RECOMMENDED AC OPERATING CONDITIONS

( $-40^{\circ}\text{C} \leq T_A \leq +85^{\circ}\text{C}$ ;  $V_{CC} = 2.7\text{V}-3.3\text{V}$ ;  $V_{CCQ} = 2.7\text{V}-3.3\text{V}$ )

AC CHARACTERISTICS		-9		-11			
PARAMETER	SYMBOL	MIN	MAX	MIN	MAX	UNITS	NOTES
READ cycle time	$t_{RC}$	90		110		ns	
Access time from CE#	$t_{ACE}$		90		110	ns	1
Access time from OE#	$t_{AOE}$		30		30	ns	1
Access time from address	$t_{AA}$		90		110	ns	
RP# HIGH to output valid delay	$t_{RWH}$		600		600	ns	
RP# LOW pulse width	$t_{RP}$	100		100		ns	
OE# or CE# HIGH to output in High-Z	$t_{OD}$		25		25	ns	
Output hold time from OE#, CE# or address change	$t_{OH}$	0		0		ns	

NOTE: 1. OE# may be delayed by  $t_{ACE}$  minus  $t_{AOE}$  after CE# falls before  $t_{ACE}$  is affected.

### READ CYCLE

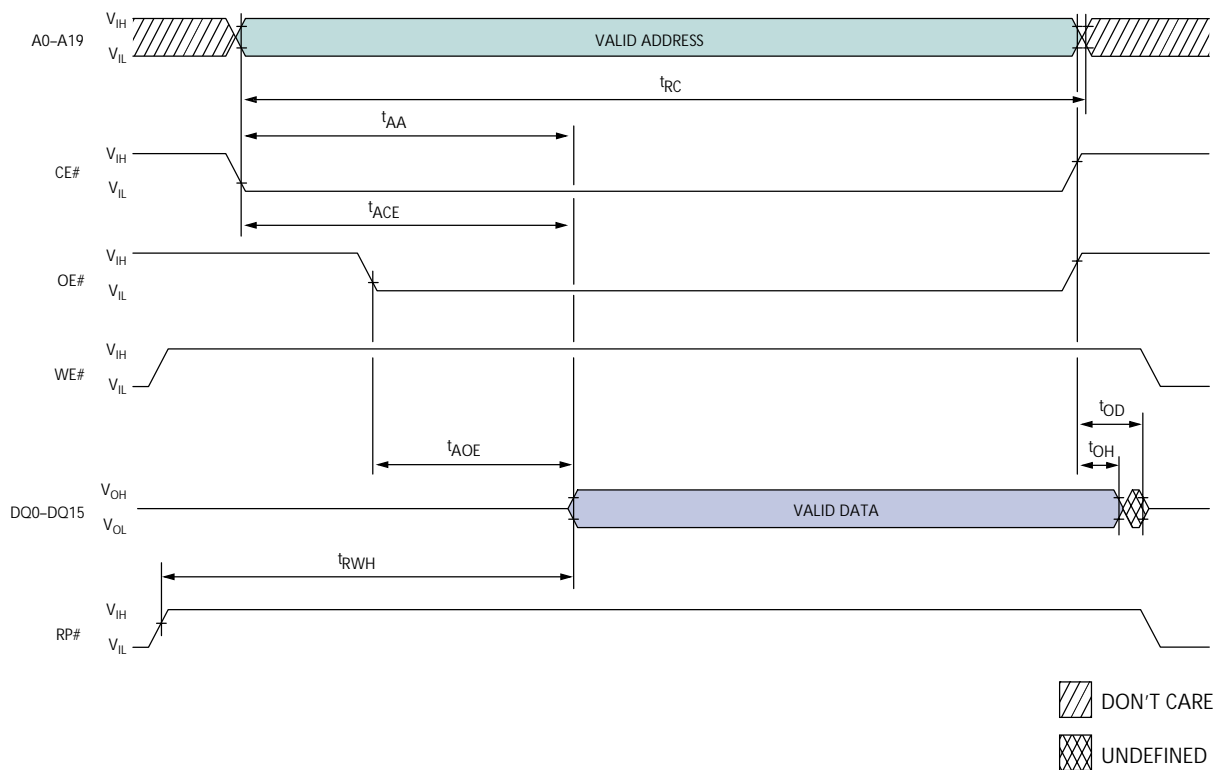

### TIMING PARAMETERS

SYMBOL	-9		-11		UNITS
	MIN	MAX	MIN	MAX	
$t_{RC}$	90		110		ns
$t_{ACE}$		90		110	ns
$t_{AOE}$		30		30	ns
$t_{AA}$		90		110	ns

SYMBOL	-9		-11		UNITS
	MIN	MAX	MIN	MAX	
$t_{RWH}$		600		600	ns
$t_{OD}$		25		25	ns
$t_{OH}$	0		0		ns

# 16 Mbit (x16) Enhanced Boot Block Flash Memory

## RECOMMENDED DC WRITE/ERASE CONDITIONS

( $-40^{\circ}\text{C} \leq T_A \leq +85^{\circ}\text{C}$ ;  $V_{CC} = 2.7\text{V}-3.3\text{V}$ )

PARAMETER/CONDITION	SYMBOL	MIN	TYP	MAX	UNITS	NOTES
$V_{PP}$ WRITE/ERASE lockout voltage	$V_{PPLK}$	-	2.0	-	V	1
$V_{PP}$ voltage during WRITE/ERASE operation	$V_{PPH}$	2.7	-	3.3	V	2
$V_{CC}$ WRITE/ERASE lockout operation	$V_{LKO}$	-	1.5	-	V	

## WRITE/ERASE CURRENT DRAIN

( $-40^{\circ}\text{C} \leq T_A \leq +85^{\circ}\text{C}$ ;  $V_{CC} = 2.7\text{V}-3.3\text{V}$ ;  $V_{PP} = 2.7\text{V}-3.3\text{V}$ )

PARAMETER/CONDITION	SYMBOL	TYP	MAX	UNITS	NOTES
WRITE CURRENT: $V_{CC} + V_{PP}$ SUPPLY	$I_{CC4} + I_{PP4}$	-	55	mA	2
ERASE CURRENT: $V_{CC} + V_{PP}$ SUPPLY	$I_{CC5} + I_{PP5}$	-	45	mA	
ERASE/PROGRAM SUSPEND CURRENT: $V_{PP}$ SUPPLY (ERASE/PROGRAM suspended)	$I_{PP6}$	50	200	$\mu\text{A}$	3

## WORD WRITE AND ERASE DURATION CHARACTERISTICS

PARAMETER	2.7V-3.3V $V_{CC}$				UNITS	NOTES
	2.7V-3.3V $V_{PP}$		5V $V_{PP}$			
	TYP	MAX	TYP	MAX		
Boot/parameter BLOCK ERASE time	0.5	4	-	-	s	4, 5
Main BLOCK ERASE time	1.0	5	-	-	s	4, 5
Boot/parameter BLOCK WRITE time	0.1	-	0.1	-	s	5, 6, 7
Main BLOCK WRITE time	0.3	-	0.3	-	s	5, 6, 7
Program/erase suspend latency	1	3	1	3	$\mu\text{s}$	

- NOTE:**
1. Absolute WRITE/ERASE protection when  $V_{PP} \leq V_{PPLK}$ .
  2. 5V  $V_{PP}$  is allowable for production programming only, not erasing. Write timings are identical to 2.7V-3.3V  $V_{PP}$  operation, and 5V  $V_{PP}$  programming current is not greater than  $I_{PP4}$ .
  3. Parameter is specified when device is not accessed. Actual current draw will be  $I_{PP6}$  plus current of operation being executed while the device is in suspend mode.
  4. The 5V  $V_{PP}$  is for programming only, not erasing.
  5. Typical values measured at  $T_A = +25^{\circ}\text{C}$ .
  6. Assumes no system overhead.
  7. Typical write times tested with checkerboard data pattern.

# 16 Mbit (x16) Enhanced Boot Block Flash Memory

## SPEED-DEPENDENT WRITE/ERASE AC TIMING CHARACTERISTICS AND RECOMMENDED AC OPERATING CONDITIONS:

### WE# (CE#)-CONTROLLED WRITES

(-40°C ≤ T<sub>A</sub> ≤ +85°C; V<sub>CC</sub> = 2.7V–3.3V)

AC CHARACTERISTICS		-9	-11		
PARAMETER	SYMBOL	MIN	MIN	UNITS	NOTES
WE# (CE#) HIGH pulse width	t <sup>WPH</sup> (t <sup>CPH</sup> )	30	30	ns	
WE# (CE#) pulse width	t <sup>WP</sup> (t <sup>CP</sup> )	70	70	ns	
Address setup time to WE# (CE#) HIGH	t <sup>AS</sup>	70	70	ns	
Address hold time from WE# (CE#) HIGH	t <sup>AH</sup>	0	0	ns	
Data setup time to WE# (CE#) HIGH	t <sup>DS</sup>	50	60	ns	
Data hold time from WE# (CE#) HIGH	t <sup>DH</sup>	0	0	ns	
CE# (WE#) setup time to WE# (CE#) LOW	t <sup>CS</sup> (t <sup>WS</sup> )	0	0	ns	
CE# (WE#) hold time from WE# (CE#) HIGH	t <sup>CH</sup> (t <sup>WH</sup> )	0	0	ns	
V <sub>PP</sub> setup time to WE# (CE#) HIGH	t <sup>VPS</sup>	200	200	ns	
RP# HIGH to WE# (CE#) LOW delay	t <sup>RS</sup>	600	600	ns	
WRITE duration	t <sup>WED1</sup>	6	6	μs	
Boot BLOCK ERASE duration	t <sup>WED2</sup>	0.5	0.5	s	
Parameter BLOCK ERASE duration	t <sup>WED3</sup>	0.5	0.5	s	
Main BLOCK ERASE duration	t <sup>WED4</sup>	1	1	s	
V <sub>PP</sub> hold time from status data valid	t <sup>VPH</sup>	0	0	ns	
WE# (CE#) HIGH to busy status (SR7 = 0)	t <sup>WB</sup>	200	200	ns	1, 2

NOTE: 1. Polling status register before t<sup>WB</sup> is met may falsely indicate WRITE or ERASE completion.  
 2. t<sup>WB</sup> = 800ns (MAX).

# 16 Mbit (x16) Enhanced Boot Block Flash Memory

## WRITE/ERASE CYCLE WE#-CONTROLLED WRITE/ERASE

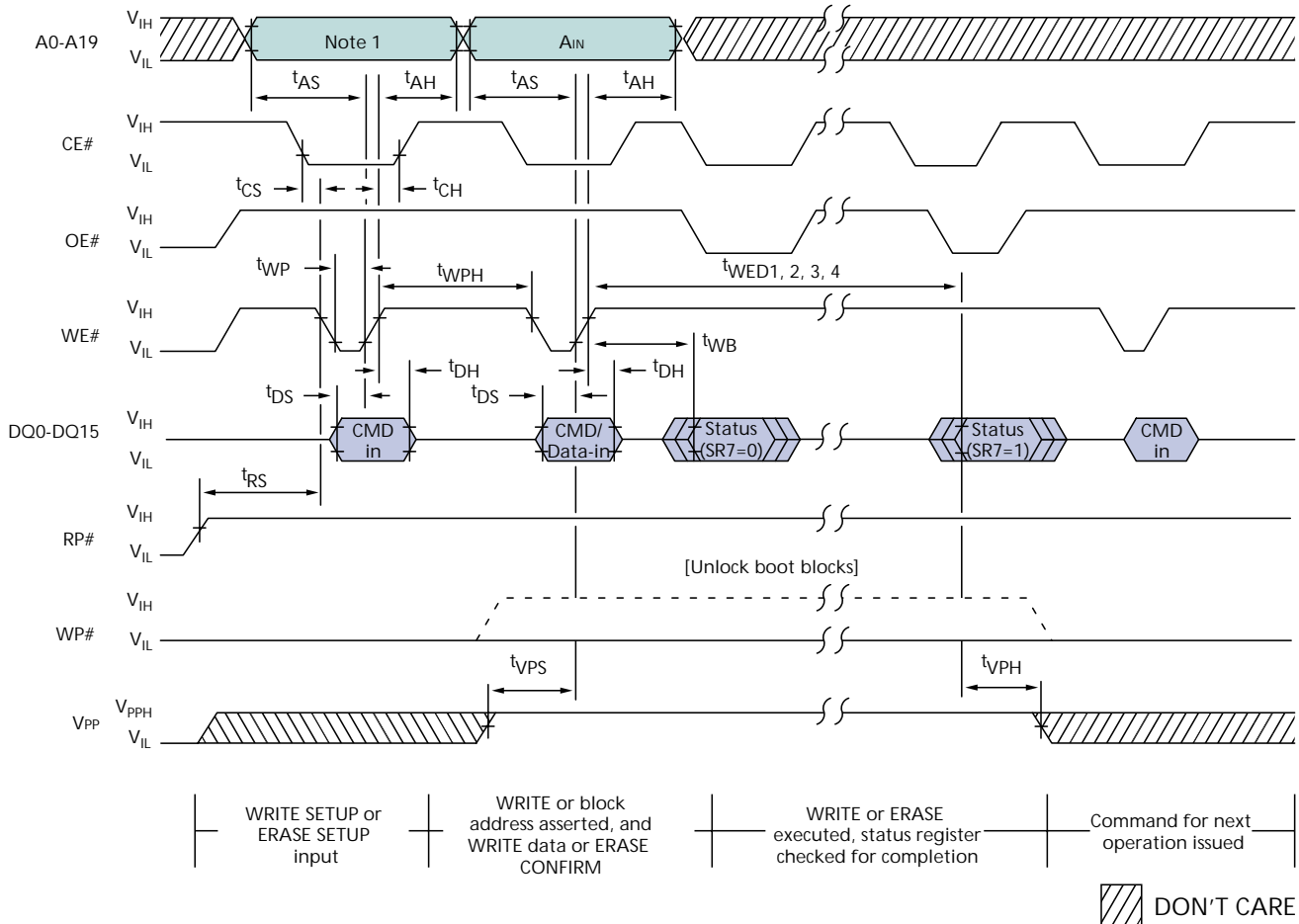

### TIMING PARAMETERS

SYMBOL	-9	-11	UNITS
	MIN	MIN	
t <sub>WPH</sub>	30	30	ns
t <sub>WP</sub>	70	70	ns
t <sub>AS</sub>	70	70	ns
t <sub>AH</sub>	0	0	ns
t <sub>DS</sub>	50	60	ns
t <sub>DH</sub>	0	0	ns
t <sub>CS</sub>	0	0	ns
t <sub>CH</sub>	0	0	ns

SYMBOL	-9	-11	UNITS
	MIN	MIN	
t <sub>VPS</sub>	200	200	ns
t <sub>RS</sub>	600	600	ns
t <sub>WED1</sub>	6	6	μs
t <sub>WED2</sub>	0.5	0.5	s
t <sub>WED3</sub>	0.5	0.5	s
t <sub>WED4</sub>	1	1	s
t <sub>VPH</sub>	0	0	ns
t <sub>WB</sub> <sup>2</sup>	200	200	ns

NOTE: 1. Address inputs are "Don't Care" but must be held stable.  
2. t<sub>WB</sub> = 800ns (MAX).

# 16 Mbit (x16) Enhanced Boot Block Flash Memory

## WRITE/ERASE CYCLE CE#-CONTROLLED WRITE/ERASE

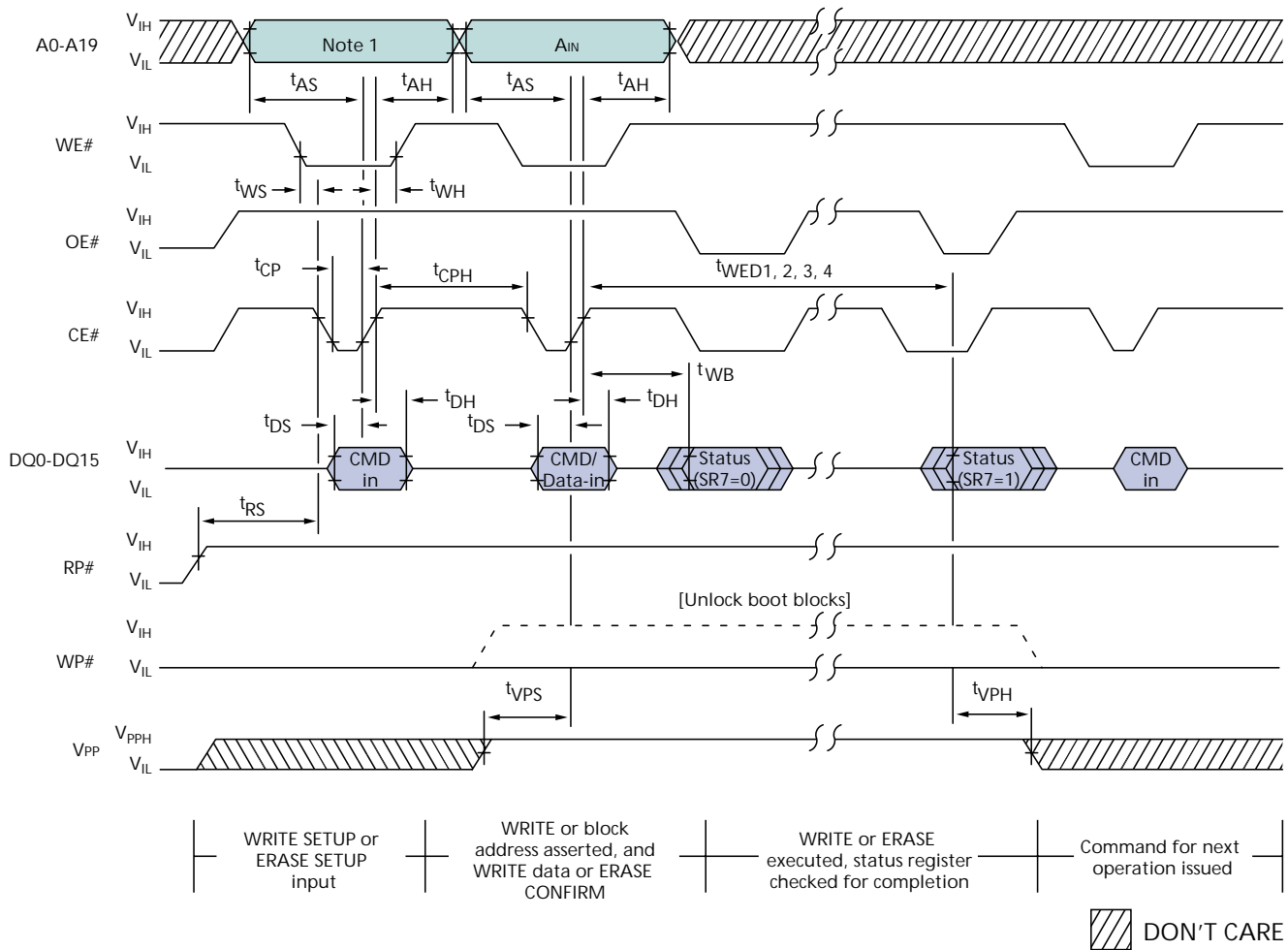

### TIMING PARAMETERS

SYMBOL	-9	-11	UNITS
	MIN	MIN	
t <sub>CPH</sub>	30	30	ns
t <sub>CP</sub>	70	70	ns
t <sub>AS</sub>	70	70	ns
t <sub>AH</sub>	0	0	ns
t <sub>DS</sub>	50	60	ns
t <sub>DH</sub>	0	0	ns
t <sub>WS</sub>	0	0	ns
t <sub>WH</sub>	0	0	ns

SYMBOL	-9	-11	UNITS
	MIN	MIN	
t <sub>VPS</sub>	200	200	ns
t <sub>RS</sub>	600	600	ns
t <sub>WED1</sub>	6	6	μs
t <sub>WED2</sub>	0.5	0.5	s
t <sub>WED3</sub>	0.5	0.5	s
t <sub>WED4</sub>	1	1	s
t <sub>VPH</sub>	0	0	ns
t <sub>WB<sup>2</sup></sub>	200	200	ns

NOTE: 1. Address inputs are "Don't Care" but must be held stable.  
2. t<sub>WB</sub> = 800ns (MAX).

# 16 Mbit (x16) Enhanced Boot Block Flash Memory

Table 6  
Command State Machine Current/Next States

Current State	COMMAND INPUTS (and next state)											
	SR7	Data when Read	Read Array (FFh)	Write setup (10h/40h)	Block erase setup (20h)	Erase confirm (D0h)	Prog./erase susp. (B0h)	Prog./erase resume (D0h)	Read SR (70h)	Clear SR (50h)	Identify device (90h)	
Read Array	1	Array	Read array	Write setup	Erase setup	Read array			Read status	Read array	Identify device	
Read Status	1	Status	Read array	Write setup	Erase setup	Read array			Read status	Read array	Identify device	
Identify Device	1	ID	Read array	Write setup	Erase setup	Read array			Read status	Read array	Identify device	
Write Setup	1	Status	Program									
Program Not Complete	0	Status	Program (not complete)				Prog. susp. status	Program (not complete)				
Program Suspend Status	1	Status	Program susp. read array	Program suspend read array		Program	Program susp. read array	Program	Program susp. status	Program suspend read array		
Program Suspend Read Array	1	Array	Program susp. read array	Program suspend read array		Program	Program susp. read array	Program	Program susp. status	Program suspend read array		
Program Complete	1	Status	Read Array	Write setup	Erase setup	Read array			Read status	Read array	Identify device	
Erase Setup	1	Status	Erase command error			Erase	Erase	Erase	Erase command error			
Erase Comd. Error	1	Status	Read array	Write setup	Erase setup	Read array			Read status	Read array	Identify device	
Erase Not Complete	0	Status	Erase (not complete)				Erase susp. to status	Erase (not complete)				
Erase Suspend Status	1	Status	Erase susp. read array	Write setup	Erase susp. read array	Erase	Erase susp. read array	Erase	Erase susp. status	Erase suspend read array		
Erase Suspend Array	1	Array	Erase susp. read array	Write setup	Erase susp. read array	Erase	Erase susp. read array	Erase	Erase susp. status	Erase suspend read array		
Erase Complete	1	Status	Read array	Write setup	Erase setup	Read array			Read status	Read array	Identify device	

# 16 Mbit (x16) Enhanced Boot Block Flash Memory

## 48-BALL FBGA

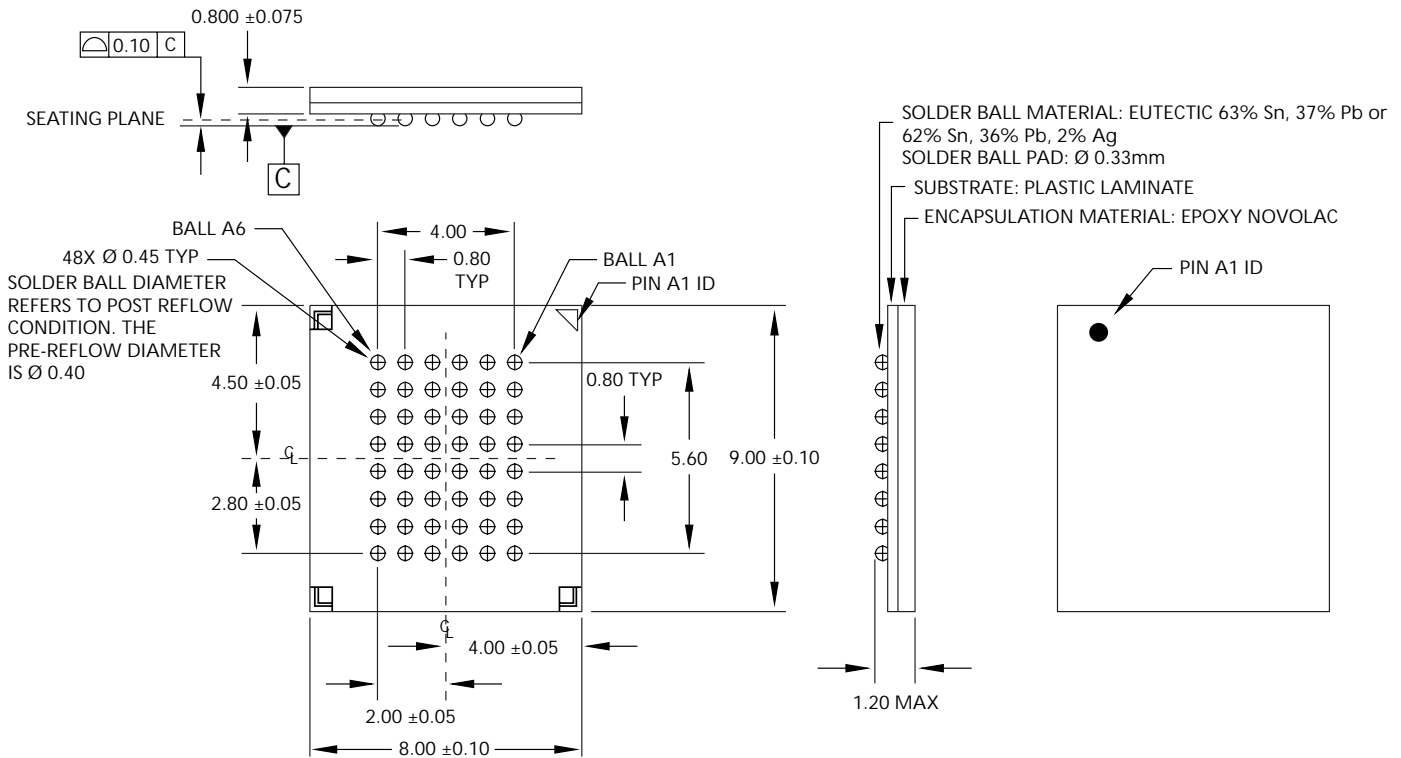

- NOTE: 1. All dimensions in millimeters  $\frac{MAX}{MIN}$  or typical where noted.  
2. Package width and length do not include mold protrusion; allowable mold protrusion is 0.33mm per side.